

AEG

SVS POWER SUPPLY
SYSTEMS

THYRO-A

THYRISTOR-LEISTUNGSSTELLER
THYRO-A 1A...H1, 2A...H1

THYRISTOR POWER CONTROLLER
THYRO-A 1A...H1, 2A...H1

Betriebsanleitung
Operating Instructions

S A F E T Y I N S T R U C T I O N S

The safety instructions and operating manual are to be carefully read prior to installation and commissioning

Obligation to give instructions

The following safety and operating instructions must be carefully read before initial assembly, installation and commissioning of Thyro-A by those persons working with or on Thyro-A.

These operating instructions are part of the Power Controller Thyro-A.

The operator of this device is obliged to provide, without restriction, these operating instructions to all persons transporting, commissioning, maintaining or performing other work on this device.

In accordance with the Product Liability Act, the manufacturer of a product has an obligation to provide explanations and warnings as follows:

- the use of the product other than for the intended use,
- the residual product risk,
- operating error and its consequences.

The information given below must be understood in this respect. It is to warn the product user and protect him and his systems.

Proper use

- The Thyristor Power Controller is a component which may only be used for control and regulation of electrical energy.
- The Thyristor Power Controller may at most be operated using the maximum admissible connected load according to information on the type plate.
- The Thyristor Power Controller may only be operated in connection with a suitable and series connected power supply disconnecting device (e.g. switch, VDE 0150 T1).
- As a component, the Thyristor Power Controller is unable to operate alone and must be projected for its intended use to minimize residual risks.

The Thyristor Power Controller may only be operated in the sense of its intended use; otherwise personal hazards, for (e.g. electric shocks, burns) and hazards for systems (e.g. system overload) may arise.

Residual hazards of the product

- Even in case of proper use, should a fault occur, it is possible that control of currents, voltages and power is no longer performed in the load circuit by the Thyristor Power Controller.

In case of destruction of the power components (e.g. break-down or high resistance), the following situations are possible: power interruption, half-wave operation, continuous power flow. If such a situation occurs, then load voltages and currents are produced from the physical dimensions of the overall power circuit. It must be ensured by system design that no uncontrolled large currents, voltages or power occur.

Maloperation and the results

- With maloperation it is possible that power, voltage or flow levels which are higher than planned reach the Thyristor Power Controller or load. On principle, this can lead to the Power Controller or load being damaged.

Transport

- Thyristor Power Controllers are only to be transported in their original packaging (protection against damage e.g. due to jolting, knocking, soiling).

Installation

- If the Thyristor Power Controller is brought into the operation room from a cold environment, moisture can occur. Prior to it being commissioned, the Thyristor Power Controller must be absolutely dry. Therefore, wait for a minimum of two hours before commissioning.

Connection

- Prior to connection, it must be ensured that the voltage information on the type plate corresponds with the mains voltage.
- The electrical connection is carried out at the designated points with the required cross section and the appropriate screw cross sections.

Operation

- The Thyristor Power Controller may only be connected to the mains voltage if it has been ensured that any hazard to people and system, especially in the load section, has been eliminated.
- Protect the device from dust and moisture
- Do not block vents.

Maintenance, service, malfunctions



CAUTION

For maintenance and repair work the Power Controller must be disconnected from all external voltage sources and protected against restarting. The voltage-free state is to be determined by means of suitable measuring instruments. This work is only to be carried out by a skilled electrician. The electrical regulations which are locally valid are to be adhered to.



CAUTION

The Thyristor Power Controller contains dangerous voltages. Repairs may only be carried out by qualified and trained maintenance personnel.



CAUTION

Danger of electric shocks. Even after disconnection from the mains voltage, capacitors may still contain a dangerously high power level.



CAUTION

Danger of electric shocks. Even when the Thyristor Power Controller is not triggered, the load circuit is not disconnected from the mains.



ATTENTION

Different components in the power section are screwed into place using exact torques. For safety reasons, power component repairs must be performed by AEG SVS Power Supply Systems GmbH.

S A F E T Y I N S T R U C T I O N S

Contents

→	Safety instructions	2
→	Safety regulations	8
→	Remarks on the present operating instructions and Thyro-A	11
→	1. Introduction	13
	1.1 General	13
	1.2 Specific characteristics	13
	1.3 Type designation	14
→	2. Functions	14
	2.1 Operating modes	14
	2.2 Set point control characteristic	15
	2.3 Control types	17
	2.3.1 Controlled value	17
	2.3.3 Controller response	17
	2.4 Indications	17
	2.4.1 LED indications	17
	2.4.2 Alarm relay K1	18
	2.5 Monitoring	18
	2.5.1 Monitoring of load and mains voltage	18
	2.5.2 Absolute value monitoring current	18
	2.5.3 Ventilator monitoring	18
→	3. Operation	18
	3.1 Configuration switch S1	18
	3.1.1 Operating mode	19
	3.1.2 Control types	19
	3.1.3 Live-zero set point	19
	3.1.4 Analog input	19
	3.2 Potentiometer R201	19
	3.2.1 Phase angle 1. half wave operation TAKT	19
	3.3 Diagnosis / status indication	00

➔	4. Phase angle 1 half wave operation TAKT	20
	4.1 Power supply for Thyro-A	20
	4.2 Power supply for the control device	21
	4.3 Impulse lock	21
	4.4 Analog output	21
	4.5 Digital set point value input	21
	4.6 Voltage transformer	21
	4.7 Operating elements and terminal strips	23
➔	5. Interfaces	24
➔	6. Mains load optimization	24
	6.1 Synchronization SYT-9 (operating mode TAKT)	25
	6.2 Synchronization in operating mode QTM (1A)	25
	6.3 Software synchronization (operating mode TAKT)	25
➔	7. Connecting diagrams	26
➔	8. Special remarks	29
	8.1 Installation	29
	8.2 Commissioning	29
	8.3 Service	30
	8.4 Checklist	31
➔	9. Type overview	31
	9.1 Thyro-A 1A ... H 1	32
	9.2 Thyro-A 2A ... H 1	32
➔	10. Technical data	33
➔	11. Dimensional drawings	35
➔	12. Accessories and options	41
➔	13. Approvals and conformities	41
	Addresses	

List of illustrations and tables

Fig. 1	Control characteristic	15
Fig. 2	Set point inputs and total set point	16
Fig. 3	Set point inputs and total set point	22
Fig. 4	Terminal plan	23
Fig. 5	Operation	24
Fig. 6	Connecting diagram Thyro-A 1A...H1	26
Fig. 7	Connecting diagram Thyro-A 2A...H1	27
Fig. 8	Connecting diagram bus modul	28
Fig. 9	Connecting diagram mains load optimization with QTM	28
Tab. 1	Behaviour with load change	17
Tab. 2	Load monitoring	20
Tab. 4	Default values DIP switch S1	29
Tab. 5	Default values potentiometer	30

➔ Safety regulations

Important instructions and explanations

Operation and maintenance according to regulations, as well as observance of the listed safety regulations is required for the protection of the staff and to maintain readiness to operate. Personnel assembling/disassembling the devices, commissioning them, operating them and maintaining them must know and observe these safety regulations.

In the present operating instructions important instructions are marked using the terms **“CAUTION”**, **“ATTENTION”** and **“REMARK”** as well as using the icons explained below.



CAUTION

This instruction indicates work and operating procedures to be observed exactly to exclude hazards to persons.



ATTENTION

This instruction refers to work and operating procedures to be observed exactly to avoid damage or destruction of Thyro-A or parts thereof.



REMARK

This is where remarks on technical requirements and additional information is given which the user must observe.

Accident prevention rules

It is imperative that the accident prevention rules of the country of application and the generally applicable safety regulations are observed.



CAUTION

Before starting any work on Thyro-A, the following safety regulations must be observed:

- switch voltage-free
- secure against switching on
- determine voltage-free state
- ground and short-circuit device
- cover or block neighbouring parts under voltage.

Qualified personnel

Thyro-A may only be transported, installed, connected, commissioned, maintained and operated by specialists in command of the respective applicable safety and installation regulations. All work must be monitored by the responsible specialist personnel.

Intended use



CAUTION

The Thyristor Power Controller may only be employed in the sense of its purpose of use (see the section of the chapter Safety Instructions under the same name), otherwise hazards to persons (e.g. electric shocks, burns) and systems (e.g. overload) may occur.

Any unauthorized reconstruction and modification of Thyro-A, use of spare and exchange parts not approved by AEG SVS as well as any other use of Thyro-A is not permitted.

The person responsible for the system must ensure that:

- safety and operating instructions are available and observed,
- operating conditions and specifications are observed,
- protective installations are used,
- maintenance personnel are immediately notified or Thyro-A is immediately put out of commission if abnormal voltages or noises, higher temperatures, vibrations or similar occur to determine the causes.

These operating instructions contain all information required by specialists for the use of Thyro-A. Additional information and notes for unqualified persons and for the use of Thyro-A outside of industrial installations are not contained in these operating instructions.

The warranty obligation of the manufacturer applies only if these operating instructions are observed.

Warranty

No liability is assumed when using Thyro-A for applications not provided for by the manufacturer. The responsibility for the necessary measures to avoid hazards to persons and property is borne by the operator or the user. In case of complaints on Thyro-A, please notify us immediately stating:

Type name	Production number
Complaint	Ambient conditions
Operating mode	Duration of use

Guidelines

The CE mark on the device confirms observation of the EC general guidelines for 72/23 EEC – low voltage and for 89/339 EEC electromagnetic compatibility if the instructions on installation and commissioning set out in the operating instructions are observed.

➔ Remarks on the present operating instructions and Thyro-A

Validity

These operating instructions correspond to the technical state of Thyro-A at the time of publication. The contents are not subject matter of the contract, but serve only as information. Modification of information contained in these operating instructions, especially technical data, operation, dimensions and weights, remain reserved at any time. AEG SVS reserves the right to content modifications and technical changes within the present operating instructions without obligation to notification. AEG SVS is not obliged to update these operating instructions constantly.

Handling

These operating instructions for Thyro-A are set out so that all work required for commissioning, maintenance and repair may be performed by corresponding specialist personnel.

Abbreviations

In this description the following specific abbreviations are used:

AEG SVS	=	AEG SVS Power Supply Systems GmbH
SYT	=	synchronized clock
TAKT	=	full wave switch mode Thyrotakt
VAR	=	phase-angle mode Thyrovar

Loss of warranty

Our supplies and services are subject to the general terms and conditions of delivery of the electrical industry as well as our general sales conditions. Any complaints on goods delivered are to be submitted, together with the delivery note, within eight days of receipt.

All guarantees made by AEG SVS and its dealers will be cancelled without prior notice if other than original AEG SVS spare parts or spare parts purchased by AEG SVS are used for maintenance and repair.

Copyright

Passing on, duplication and/or takeover of these operating instructions by electronic or mechanical means, including excerpts, is subject to the express prior written approval of AEG SVS.

© Copyright AEG SVS Power Supply Systems GmbH 2002.
All rights reserved.

Additional remark on copyright

Thyro- is an internationally registered trademark of AEG SVS Power Supply Systems GmbH.

Windows and Windows NT are registered trademarks of the Microsoft Corporation. All other companies and product names are the (registered) trademarks of the respective owners.

➔ 1. Introduction

Thyro-A has been conceived to meet the demands for simple assembly, speedier commissioning and safer operation.

For transport, assembly, installation, commissioning, operation and decommissioning, it is essential that the safety instructions included in these operating instructions are observed and made available to all persons handling this product.

In case of uncertainties or missing information, please contact your supplier.

The described operating mode QTM is being prepared.

1.1 General

Thyro-A is a Thyristor Power Controller with the ability to communicate. It will also simply be referred to as Power Controller or Controller. It can be used wherever voltages or currents need to be controlled or regulated in processing technology. Thyro-A's distinguishing features are its several operating and control modes, good coupling ability to process and automation technology, high control precision and simple handling through a 16-Bit processor.

1.2 Specific characteristics

Thyro-A has a wide range of specific characteristics, for instance:

- ➔ easy handling
- ➔ type range 230-500 Volts, 8-280 A, single and double phase
- ➔ ohmic load and transformer load
- ➔ soft start function for transformer load
- ➔ control modes U, U²
- ➔ operating modes TAKT, as well as VAR and QTM with Thyro-A 1A
- ➔ control with analog set points and / or via optional bus adapter
- ➔ series system interface
- ➔ electrical separation according to EN 50178 chapt. 3

Options:

- ➔ bus connections via bus adapter
coupling to different bus systems, e.g. Profibus DP, Modbus RTU, other bus systems on request.

1.3 Type designation

The type designation of the Thyristor Power Controllers is derived from the construction of its power section.

Thyro-A 1A	Power Controller with single phase power section suited for single phase loads
Thyro-A 2A	Power Controller with double phase power section suited for three phase operation in three phase saver circuit

Example

Thyro-A 1A	Power Controller with single phase power section
...400-	with 400 Volt type voltage
...280	with 280 Amp type current
H	with integrated semi-conductor fuse
F	with ventilator (only 280 Amp types)
1	designation Thyro-A, 2002 series

The complete type range can be found in chapter 9, TYPE OVERVIEW.

➔ 2. Functions

To enable Thyro-A to adjust optimally to the desired application, it is equipped with a wide range of functions. These are described below. Further functions are possible by applying Thyro-A within a bus system. See also chapter 5 INTERFACES.

2.1 Operating modes

For adjustment to different electrical loads, the most favourable operating mode can be chosen.

Full wave switch TAKT (for 1A, 2A)

Depending on the prescribed set point, the mains voltage is periodically switched. In this operating mode almost no harmonics are created. Whole multiples of the mains periods are switched, thus avoiding d.c. components. The full wave switch mode is especially suited for loads with thermal inertia. Depending on the function angle 1. half wave, the phase frequency is adjusted independently to 5 or 50 mains periods = T_0 .

The phase operation creates minimal mains reactions. Should there be a flicker, this can be minimized with the aid of the mains load optimization.

Phase-angle principle VAR (for 1A)

Depending on the prescribed set point, the sine oscillation of the mains voltage is gated using a larger or smaller control angle α . This operating mode is characterized by high control dynamics.

With phase-angle control harmonics of the mains voltage occur. It is possible to compensate these by using circuit variants.

Half-wave switch mode QTM (Quick-Takt-Mode for 1A)

QTM is the patented fast operating mode which works on the half wave switch principle. Depending on the prescribed set point, mains half waves are switched. D.c. components are avoided for the phase duration. The fast phase control is particularly suited for IR beams as an alternative to phase-angle control. When using several controllers it is possible, by synchronisation, to keep the mains reactions small.

2.2 Set point control characteristic

The set point control characteristic of Thyro-A can easily be adapted to the control output signal of an upstream process controller or automation system. All signals customary on the market may be used. The adaption is made by changing the starting and ending points of the control characteristic.

If the controller is within a limit (U_{max}), both red LEDs blink alternatively in second intervals (chapt. 3.3).

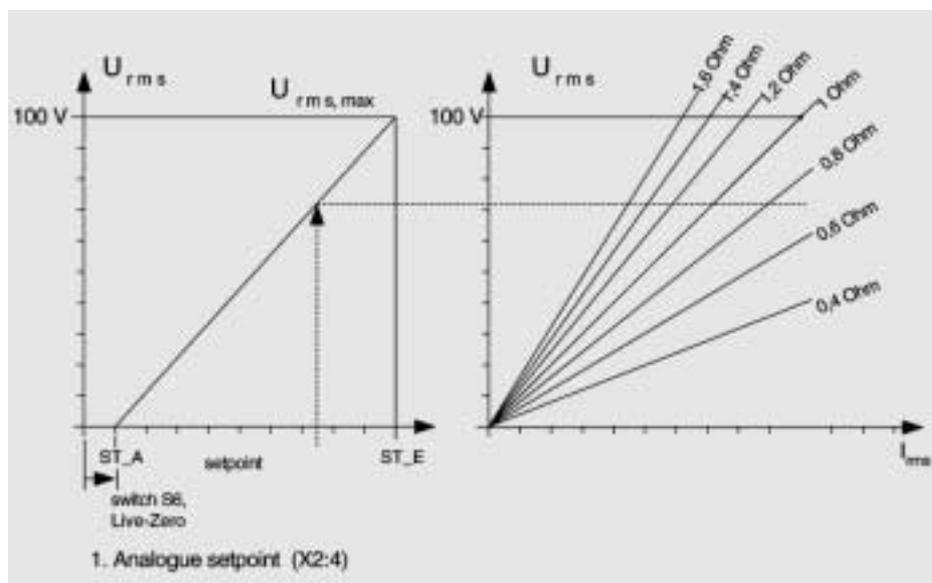

Fig. 1 Control characteristic analog input

Input set points

The Power Controller Thyro-A is equipped with two input set points which are isolated from the mains.

- Set point 1 analog (X2.4 – X2.3 ground)
- Set point 2 system interface

The analog input can be adapted to the various process controllers by means of the set point and live zero set point switches. The following signal ranges can be set:

0(4)-20mA ($R_i = \text{ca. } 250\Omega$), 0-5V ($R_i = \text{ca. } 44\text{k}\Omega$), 0-10V ($R_i = \text{ca. } 88\text{k}\Omega$).

Within the stated input ranges these values with the control characteristic may be adjusted to any common signal characteristic.

+5V supply voltage can be taken for a set point potentiometer from terminal X2.8 ($5\text{k}\Omega \leq R_{\text{poti}} \leq 10\text{k}\Omega$).

The effective set point is the total set point. It is made by adding the two set points. It is either the analog set point or the bus set point. If the bus module is connected and in operation, the bus set point is effective.

If the bus module or bus (e.g. Profibus-DP) is interrupted, the controller automatically switches to the analog set point.

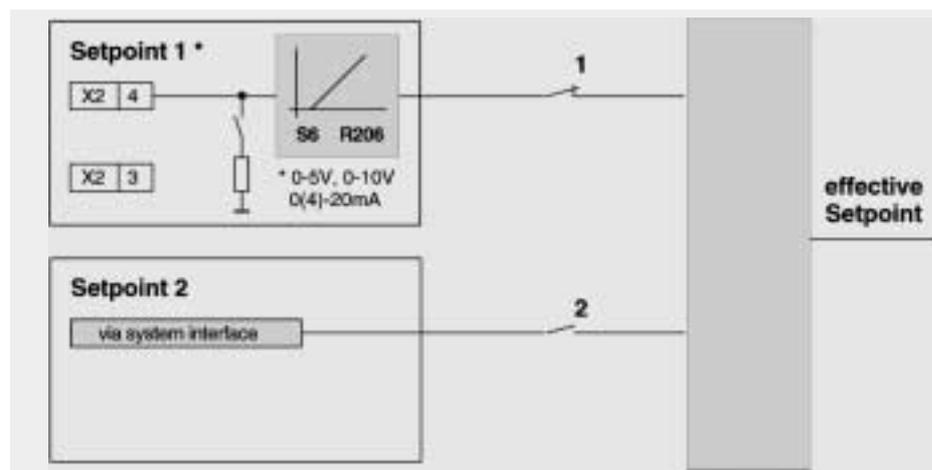

Fig. 2 Set point inputs and total set point

2.3 Control types

Thyro-A ...H 1 has two control types. Mains voltage variations and load changes are directly and quickly adjusted by bypassing the sluggish temperature control system.

Before commissioning the Power Controller and selecting a control mode, familiarisation with the operating procedure and the effect upon the application is important.

2.3.1 Controlled value

The controlled value effective on the load is proportionate to the total set point, depending on the control type.

Control type	Control value (proportionate to the total set point)
U	output voltage, U_{rms}
U^2	output voltage, U_{rms}^2

2.3.2 Controller response

If the load resistance changes, e.g. due to temperature effect, ageing or load fault, the values effective on the load change as follows:

Underlying control	Underlying limit	Load resistance decreases			Load resistance increases			
		P	U_{Load}	I_{Load}	P	U_{Load}	I_{Load}	
U	$U_{rms\ max}$	larger	=	larger	smaller	=	smaller	
U^2 (UxU)	$U_{rms\ max}$	larger	=	larger	smaller	=	smaller	

Tab. 1 Behaviour with load change

2.4 Indications

2.4.1 LED indications

The LEDs on the front signal the following states:

• ON	green	operating indication, power supply controller device
• PULSE INHIBIT	red	pulse lock active

Blinking indications are described in chapter 3.3.

2.4.2 Alarm relay

Unlike the types Thyro-A...H RL1, the Power Controllers of type Thyro-A...H1 have no alarm relay.

2.5 Monitoring

Faults occurring in the Power Controller are signalled. Signalling ensues via red LED.

2.5.1 Monitoring of the load and mains voltage

The limiting values of the voltage are -57% of the type voltage for undervoltage monitoring and +10% of the type voltage for overvoltage monitoring. This produces the following absolute limiting values:

Type	Undervoltage	Overvoltage
230V	99V	253V
400V	172V	440V
500V	215V	550V

2.5.2 Equipment temperature monitoring

The control board is equipped with a temperature monitor. In case of a fault the red LED blinks.

2.5.3 Ventilator monitoring

The separately ventilated power controllers (...F...) are fitted with thermal monitoring. The temperature of the heat sink is measured. In case of a temperature over-range a fault indication ensues.

➔ 3. Operation

This chapter describes the operating elements of Thyro-A. For default settings see chapter 8.2.

3.1 Configuration switch S1

A 8-pole DIP switch is situated at the front behind the hood. The individual switches are marked from 1–8 starting from the bottom and must be set before operation

according to application. They are only read in by the Power Controller once when switched on or with mains recovery. For safety reasons further operation is carried out with the hood closed. (3.2).

3.1.1 Operating mode

<u>S1-</u>	<u>1</u>	<u>2</u>	<u>Operating mode</u>
	0	0	none
	1	0	TAKT - Operating mode
	0	1	VAR - phase-angle operation
	1	1	QTM - Quick takt operation

3.1.2 Control type

<u>S1-</u>	<u>3</u>	<u>4</u>	<u>5</u>	<u>Control type</u>
	0	0	0	U ² (UxU)
	1	0	0	U (U)

3.1.3 Live zero set point

<u>S1-</u>	<u>6</u>	<u>Signal level</u>
	0	0 - 20mA
	1	4 - 20mA

3.1.4 Analogeingang

<u>S1-</u>	<u>7</u>	<u>8</u>	<u>Signal level</u>	<u>Eingangswiderstand</u>
	0	0	0 - 10V	88kΩ
	1	0	undefined	undefined
	0	1	0 - 5V	44kΩ (e.g. for set point potentiometer)
	1	1	0 - 20mA	250Ω

3.2 Potentiometer R201

3.2.1 Phase angle 1. half wave (TAKT operation)

Potentiometer R201 serves to set the transformer load. At works it is set at 60° el with Thyro-A 1A and at 90° el with Thyro-A 2A.

Transformer loads with a nominal induction > 1.2 T, as well as wound core and toroidal core transformers optimization is necessary. With Thyro-A 1A generally 80°el turn (to the right), with Thyro-A 2A turn at smaller angles (to the left). An optimal setting is achieved when the rush current is minimal.

The soft start time SST is set at the same time. The also applies to the operating mode **VAR**.

Depending on AN1 the soft start time has the following values:

AN [1°el]	<30	<33.7	>=33.7	>=41.2	>=48.7	>=56.2	>=61.5	>=64.5	>=67.4	>=70.5	>=73.5
SST [ms]	0	120	140	160	180	200	220	260	300	400	600
Rev.	<7	7.5	8	9	10	11	12	12.5	13	13.5	14

With a solely ohmic resistance load the poti can be turned to the left limit stop, at < 30°el Thyro-A independently switches to a faster pulse operation with To = 5 periods without SST. In this configuration the terminal X2.7 can be used as an additional digital "set point value" (24V d.c.). This also permits the controller to be driven by a 2-point controller.

3.3 Diagnosis / status indications

Faults can occur in the load circuit and in the controller itself or from the mains. Diagnosis of unexpected operating behaviour is performed by LEDs on the front panel of the control device.

Description	LED's	Description
Frequency fault	PULSE INHIBIT blinks	Outside 47Hz to 63Hz when switching on or Zero crossing outside permissible tolerance range in operation
SYNC fault	PULSE INHIBIT blinks	Temp. monitoring responded (control board or control section)
Temperature monitoring	red LED blinks	Mains fault
Flash values invalid	2 red LEDs	Mains fault
Correction values invalid	blink synchron	Bridge X2: 1.2 opened
Undervoltage	PULSE INHIBIT	U limit value exceeded
Pulse lock active	PULSE INHIBIT	
U limitation	2 red LEDs blink slowly, alternatively	

Tab. 2 Allocation of message register

➔ 4. External connections

4.1 Power supply for Thyro-A

Connecting the power supply is carried out as shown in the figures and TECHNICAL DATA. With Thyro-A 2A a right rotational field in the power circuit is required.

4.2 Power supply for the control device

The control device is supplied directly from the power section (terminals U1, X1:1.2). This voltage also serves as mains synchronization. The mains connection is equipped for input voltages of $U_{nom} - 15\%$ to $+10\%$ and nominal frequencies of 47Hz to 63Hz. Both terminals (X1:1.2 1.5mm² grid 3.81) are internally bridged. If a phase is connected to X1, a fused connection is necessary (figs. 3, 7).

4.3 Pulse lock

The pulse lock (PULSE INHIBIT; terminals X2.1 - X2.2 1.5mm², grid 3.5) is activated by opening the pulse-lock bridge, i.e. the power section is no longer triggered. If the pulse lock is activated the LED "PULSE INHIBIT" lights up red. It is imperative to use the pulse lock with transformer load in order to activate the Soft Start function. It may only then be released when there is a voltage supply to the power section. With Thyro-A 2A the pulse lock is only wired to the master (L1, left).

4.4 Analog set point value input

The set point value input (terminal X2: 3 ground - X2:4 + 1.5mm² grid 3.5) is suitable for process controllers with output signals of 0(4) - 20mA, 0-5V, 0-10V.

4.5 Digital set point value input

Under certain conditions terminal X2.7 can be used as additional digital "set point value input" (24V d.c.) so that, for instance, Thyro-A can be triggered by a 2-point regulator. Further information is available on this in chapter 3.2.1.

4.6 Voltage transformer

The load voltage is recorded by the measuring signal given by the supply voltage. This value is linked with the control angle α or the pulse ratio $U_{rms} = U_{mains} \cdot \sqrt{T_S/T_O}$. The voltage transformer only has local mode wiring.

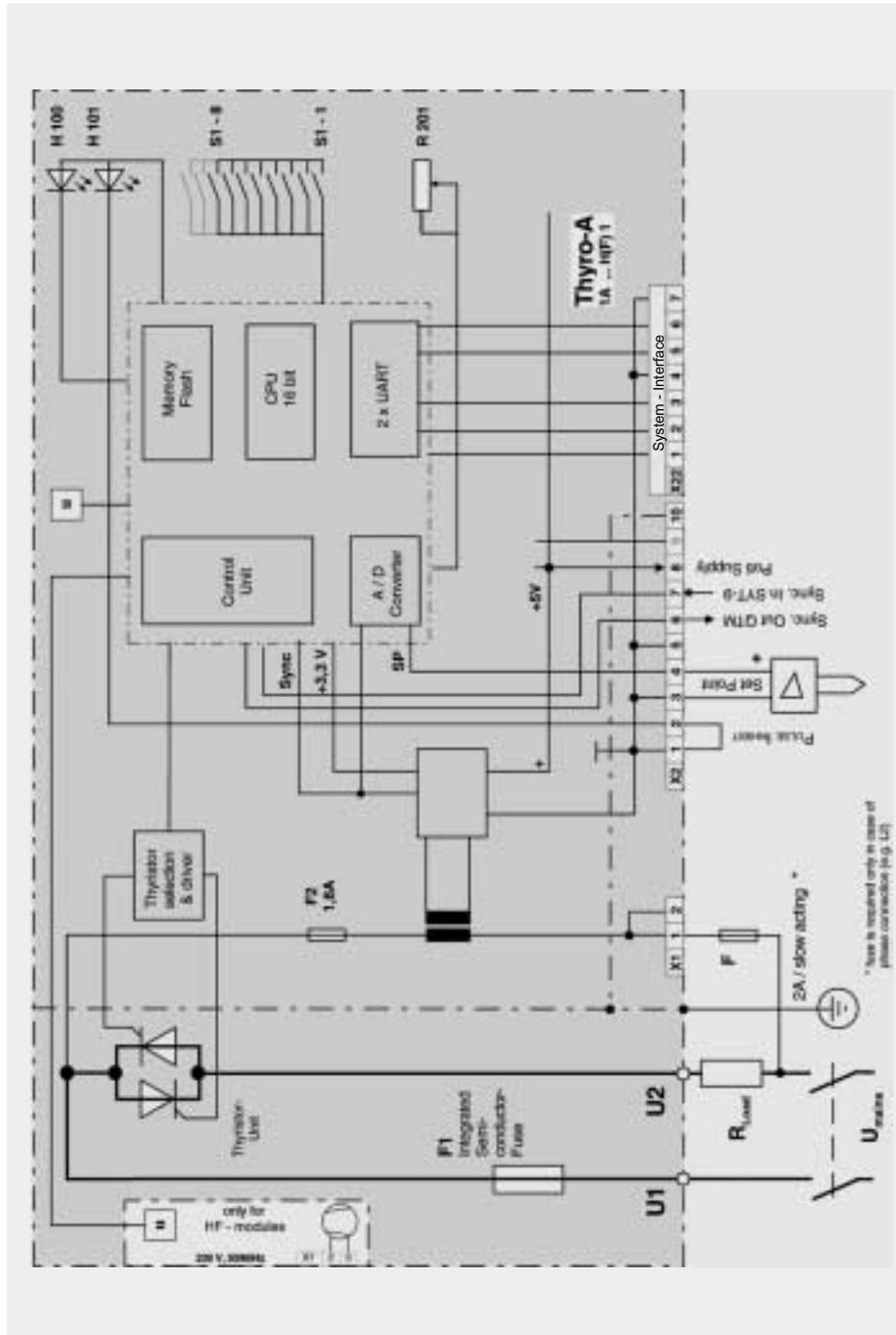

Fig. 3: Block connecting diagram

The above block connection diagram shows the basic functions of Thyro-A...H1.

4.7 Operating elements and terminal strips

This chapter describes all terminal strips and jumpers.

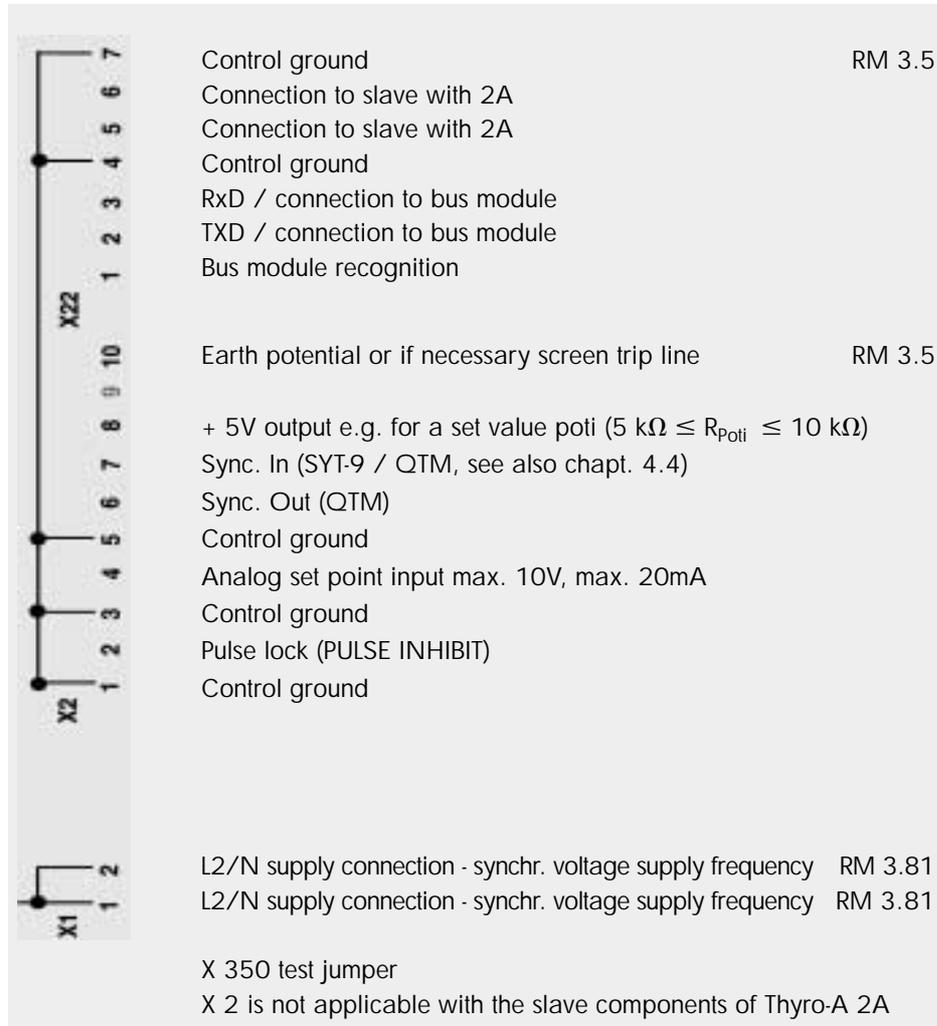

Fig. 4: Terminal plan

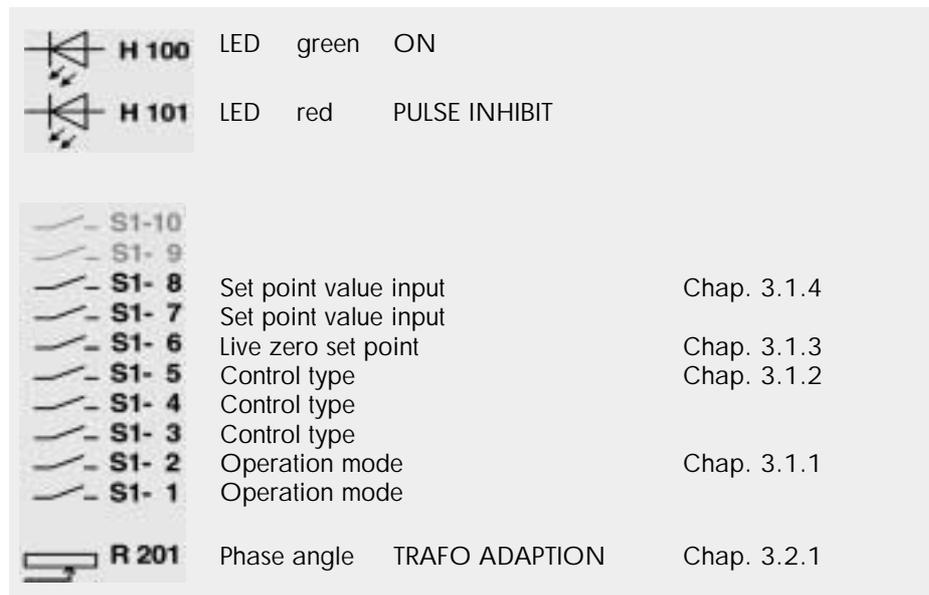

Fig. 5: Operation

➔ 5. Interfaces

With its system interface terminal strip X22 the Power Controller Thyro-A can be connected via an optional bus module to, for example, Profibus DP or Modbus RTU (other bus modules available on request). Description and connections can be taken from the instructions of the respective components.



REMARK

The access to set value, actual values and parameters made possible through bus provides further useful functions for application, e.g. software synchronization. The corresponding operating instructions provide further information on this.

➔ 6. Mains load optimization

Thyro-A can be operated in multiple controller applications with mains load optimization. The application of mains load optimization offers substantial advantages, e.g. reduction of mains load peaks and mains reactions.

Mains load optimization is possible in multiple controller applications in which either the operating mode TAKT (slow pulse at $AN_1 \geq 30^\circ\text{el}$) or operating mode QTM is applied.

6.1 Synchronization SYT-9 (operating mode TAKT)

SYT-9 is a process for static load optimization. It minimizes main load peaks and associated mains reaction shares. Set points and load changes are not automatically included in mains load optimization.

The SYT-9 process requires an additional component. It can also be employed in connection with AEG controllers already installed. Then the pulse must be connected to terminal X2.7 and the +5V for the SYT-9 card must be connected to X2.8.

The operating mode TAKT contains a high pulse frequency ($AN1 < 30^\circ el$ for ohmic load, $T_o = 5$ supply periods) as well as a low pulse frequency ($T_o = 50$ supply periods). The low pulse frequency is also suitable for switching transformers and is activated independently at phase angle $> 30^\circ el$.

Only in this operating mode is the input X2:7 scanned. If a pulse is recognised, impulse is switched on and the pulse time T_o applies from here.

The impulse is switched by the Synchrotakt component via an optoelectronic coupler. Energy comes from its own controller (X2.8).

Please observe the operating instructions of the SYT-9 component.

6.2 Synchronization in operating mode QTM (1A)

In the operating mode QTM the synchronization of 2-12 controllers is possible.

The operating mode QTM works in rapid half-wave frequency with a pattern of switched and locked half waves at particular intervals < 1 sec, also designated as T_o . To achieve a balance in supply from the outset (not after T_o) the individual controllers synchronize themselves by staggering by one supply period. With the first connected controller the SYT input X2.7 is jumped to +5V X2.8.

The following controllers receive their impulses at X2.7 from sync. output X2.6 of the previous controller. With the last controller X2.6 remains free (series connection).

This synchronization method is only possible with Thyro-A 1A (see Fig. 9).

6.3 Software synchronization (operating mode TAKT)

The application of an optional bus module activates the software synchronization.

➔ 7. Connecting diagrams

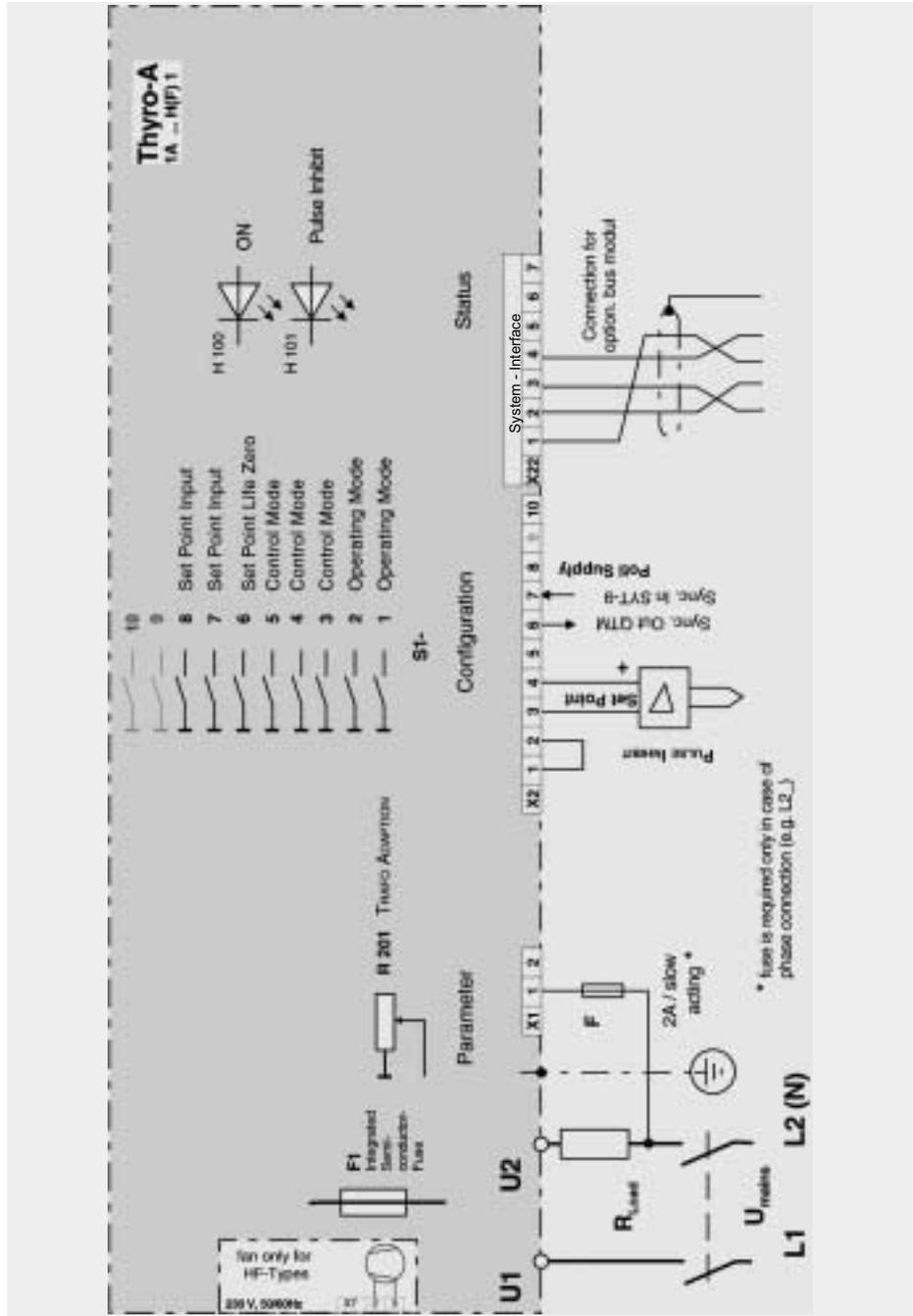

Fig. 6: Connecting diagram Thyro-A 1A...H1

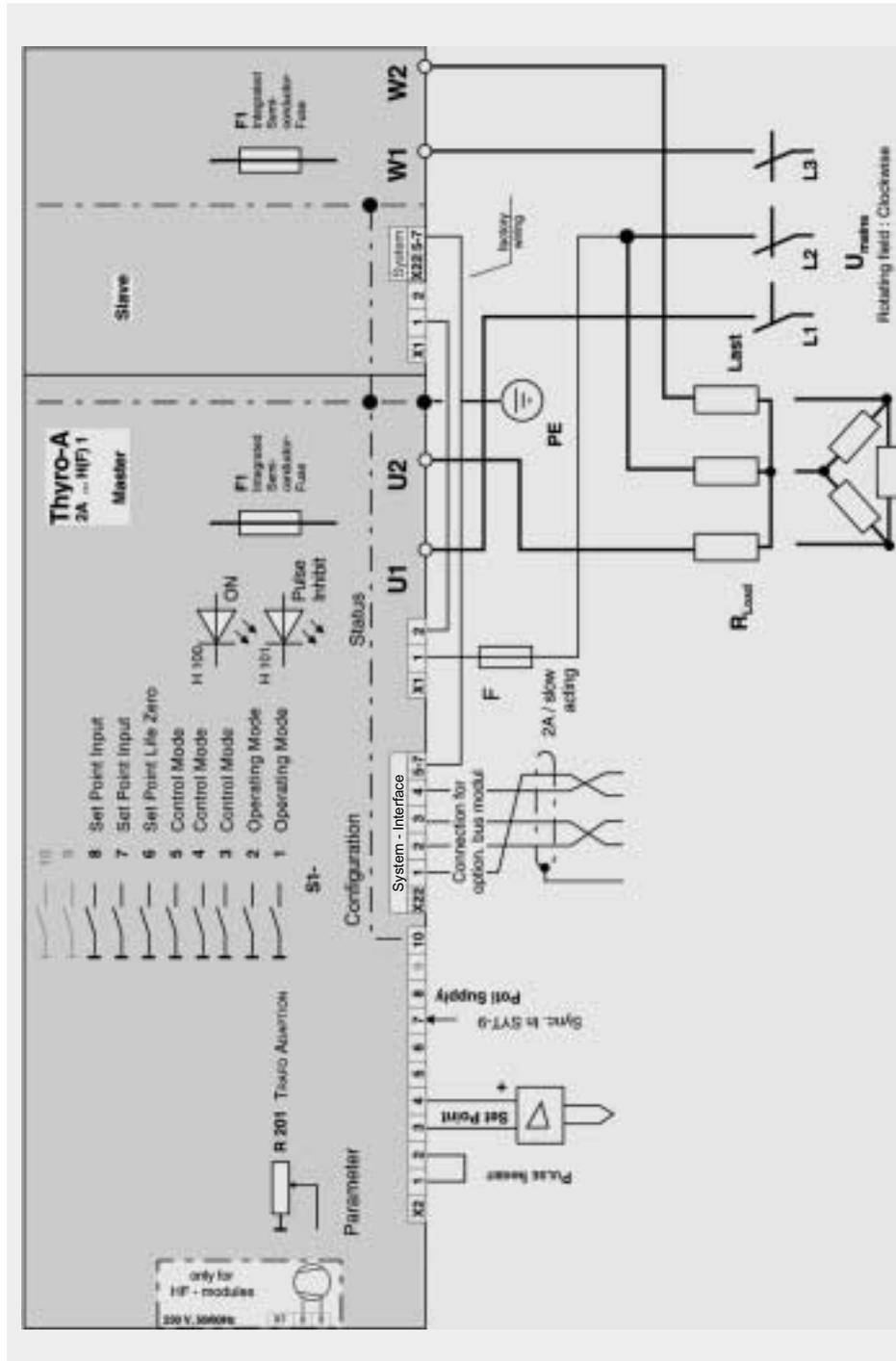

Fig. 7: Connecting diagram Thyro-A 2A...H1

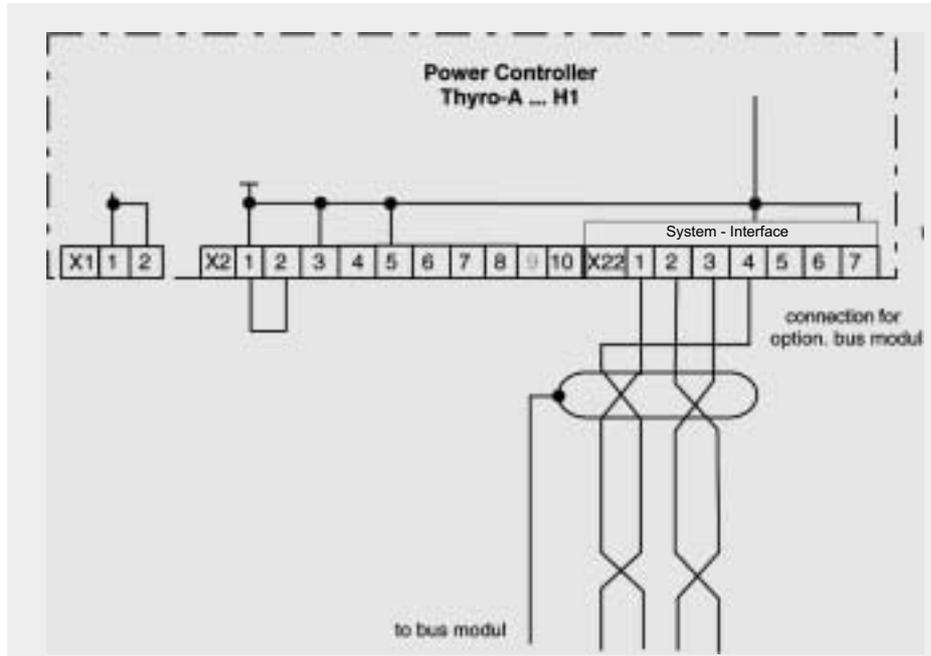

Fig. 8 Connecting diagram bus modul

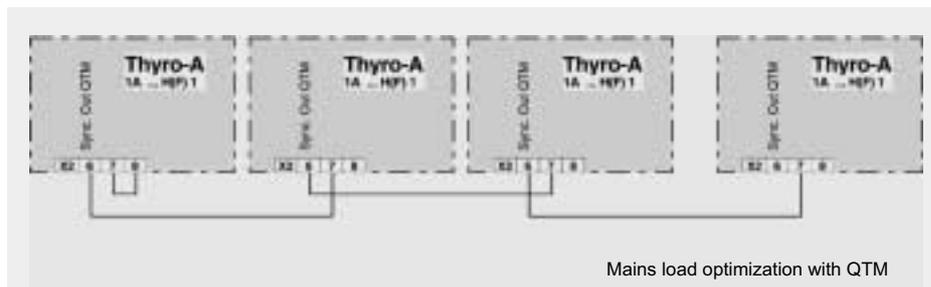

Fig. 9 Connecting diagram mains load optimization with QTM

➔ 8. Special remarks

8.1 Installation

Thyro-A requires a vertical fitting position. With cabinet mounting sufficient ventilation of the cabinet must be ensured. The distance between the Power Controller and the cabinet ceiling or other mountings should be at least 150mm. The distance below the Power Controller should be at least 100mm. Heating up of the device by heat sources must be avoided. The dissipation of the Power Controller is stated in the Type overview table.



ATTENTION

Grounding must be carried out according to local regulations! (grounding screw for protective conductor connection on fastening adapter).

The grounding also serves EMV devices (Y capacitor 4.7 nF).

For single-phase devices with type currents 8A, 16A or 30A an adapter can be delivered for the 35mm top-hat rail assembly.

8.2 Commissioning

The device must be connected to the mains and the associated load according to the corresponding connecting plans.

On delivery the device is parameterized and adjusted to the respective power section. The operating mode TAKT (S1-1, S1-2) for transformer load (R201) is set. If a different operating mode is desired, then it must be set by the user. The following table shows the default settings of the DIP switch.

Analog input		Default	Setting act. Setting	Chapter No.
S1-8	Signal level	0-20mA		3.1.4
S1-7				
S1-6	Life Zero	0mA		3.1.3
Control mode				
S1-5	Control mode	U ²		3.1.2
S1-4				
S1-3				
Operating mode				
S1-2	Operating mode	TAKT		3.1.1
S1-1				

Tab. 4 Default values DIP switch S1

The default settings of the potentiometer can be taken from the following table.

Phase angle 1. half wave		Default	Setting act. Setting	Chapter No.
R201		Thyro-A 1A: 60° el. Thyro-A 2A: 90° el.		3.2.1

Tab. 5 Default values potentiometer

All standard settings should be checked by the user as a matter of course and adjusted to the operating conditions (e.g. operating mode, control mode, limits, monitoring, control characteristics, actual value output, fault indications etc.)



REMARK

Apart from the load and current supply to X1.1, certain control signals must be connected too. The following signals are essential for operating the device:

Set point	(terminal 4 or by system interface)
Pulse lock	(on ground, on terminal 1,2; jumper)

If the pulse lock jumper is not connected, the device is in a locked state and will not operate. Communication via interface is still possible. Further details on the pulse lock are described in the chapter of the same name.



ATTENTION

Heat sinks and neighbouring plastic parts are hot during operation (> 70°C)! Provided sign should be fixed nearby Thyro-A.

8.3 Service

The devices delivered have been produced under quality standard ISO 9001. Should nevertheless faults or problems occur, our 24-hour service hotline: Tel: 02902 / 763-100. is at your service.

8.4 Checklist

- **LED ON green does not light up**

- Check fuse control 500V 1.6 A, if defective check external wiring, also applies to faults of external fusing.
- Check Power Controller fusing. If fuse is defect then check load and wiring to load. Synchronization voltage is supplied to X1.1.
- With transformer load, check phase angle 1 (TRAFO ADAPTION) - fuse release caused by rush current is possible if setting is incorrect.
- Check 5 Volt to X2.8. If this voltage is absent or too low, there is a defective component.

- **Supply available but no load current**

- Check that pulse lock is cleared (jumpered) terminal X2.1,2
- Check set point
- Check for load interruption
- Check blinking LED indications (chapt. 3.3)

- **Load current does not have expected value**

- Check set point Terminal X2.4 against X2.3 ground or Bus set point (with optional bus module)
- Set point/controller value, max. value correctly parameterized
- Check all parallel load resistances for current conduction
- Check control end for correct setting
- Check control characteristic adjustment (U, live zero)

- **Load current flows uncontrolled**

- In rare cases a Thyristor short-circuit can occur.

➔ 9. Type overview

The type key comprises from left to right:

Type range	Thyro-A
Number of controlled phases	1A, 2A
Mains supply voltage	230, 400, 500 (V)
Type current	30 ... 280 (A)
and designation	H(F) 1
for integrated semiconductor (H), with increased ventilation (F) and characteristic 1 for "series 2002".	

9.1 Thyro-A 1A...H 1

Thyristor controller with incorporated semiconductor, system bus interface, synchronization option (for TAKT: with integrated SYT9, for QTM), with operating modes TAKT, VAR, QUICK-TAKT-MODE (T-V-Q) and the control types U, U²

Type 1A	Current [A]	Type capacity [kW]			Dissipation [W]	Dimens. in mm / kg				Dim. draw.	Current transf.	Fuse F1
		230V	400V	500V		W	H	D	Weight			
H 1	8	1.8	3.2	4		40	121	127	0.5	910		12
H 1	16	3.7	6.4	8	30	45	121	127	0.7	911	40	20
H 1	30	6.9	12	15	47	45	121	127	0.7	911	40	40
H 1	45	10	18	22.5	48	52	190	182	1.7	943	100	63
H 1	60	14	24	30	80	52	190	182	1.7	943	100	100
H 1	100	23	40	50	105	75	190	190	1.9	944	100	180
H 1	130	30	52	65	150	125	320	237	4	946	150	200
H 1	170	39	68	85	210	125	320	237	4	946	200	315
HF 1	280	64	112	140	330	125	370	237	5	948	300	350

9.2 Thyro-A 2A...H 1

Thyristor controller with incorporated semiconductor, system bus interface, synchronization option (with SYT9). Suitable for 3-phase operation in 3-phase economy circuit with operating mode TAKT and the control types U, U²

Type 2A	Current [A]	Type capacity [kW]			Dissipation [W]	Dimens. in mm / kg				Dim. draw.	Current transf.	Fuse F1
		400V	500V	W		H	D	Weight				
H 1	8		5.5	7		80	121	127		000		12
H 1	16		11	14	60	90	121	127	1.4	001	40	20
H 1	30		21	26	94	90	121	127	1.4	001	40	40
H 1	45		31	39	96	104	190	182	3.4	003	100	63
H 1	60		42	52	160	104	190	182	3.4	003	100	100
H 1	100		69	87	210	150	190	190	3.8	004	100	180
H 1	130		90	112	300	250	320	237	8	006	150	200
H 1	170		118	147	420	250	320	237	8	006	200	315
HF 1	280		194	242	660	250	393	237	11	008	300	350

➔ 10. Technical data

Type voltage	230 Volt -57% +10% 400 Volt -57% +10% 500 Volt -57% +10%
Mains frequency	all models 47Hz to 63Hz; $\Delta f=6$ Hz; max. frequency change 5% per half wave
Load description	ohmic load transformer load



ATTENTION

The induction of the load side transformer should not exceed 1.45T in case of mains overvoltage when using grain-oriented, cold-rolled plates = 1.2T nominal induction.

Operating modes

TAKT =	full wave pulse = default setting (TO: 0.1 sec / 1.0 sec)
VAR =	phase-angle control (only Thyro-A 1A)
QTM =	fast half wave pulse (only Thyro-A 1A)

Set point inputs

The Power Controller Thyro-A has 2 set point inputs. The set point inputs are safely disconnected from the mains (SELV, PELV).

Set point 1: External set point input signal ranges:

0(4)-20 mA	$R_i = \text{ca. } 250 \Omega$
0-5 V	$R_i = \text{ca. } 44 \text{ k}\Omega$
0-10 V	$R_i = \text{ca. } 88 \text{ k}\Omega$

Set point 2: System interface, connection from superset PC or automation system

Control characteristic

The control characteristic is established by the maximum value of the dimensions to be controlled and the key values of the set point. Using these key values, the linear control characteristic may be set as desired.

Each controller (e.g. temperature controller) whose output signal lies within the range 0-20mA / 0-5 V / 0-10 V, can easily be adapted to the Power Controller.

Control types

Voltage control U_{rms} , U_{rms}^2 (default setting)

Precision of control

In all ranges better than $\pm 2.5\%$ and ± 2 digits with reference to the end value.

Ambient temperature

35°C external cooling (F model with integrated ventilator)

45°C self air cooling

At higher temperatures it is possible to operate with reduced type current:

Temperature range up to 55°C: type current -2% /°C

Power connections

Type current	Connector U1, U2	Earthing screw	Conductor cross sect.
8 A	Screw plug-in terminal	Bracket / M4	4 mm ² , max.
16 A	Bracket / M4	Bracket / M4	6 mm ² , max.
30 A	Bracket / M4	Bracket / M4	6 mm ² , max.
45 A	M 6	M 6	50 mm ² , max.
60 A	M 6	M 6	50 mm ² , max.
100 A	M 6	M 6	50 mm ² , max.
130 A	M 8	M 10	95 / 120 mm ²
170 A	M 8	M 10	95 / 120 mm ²
280 A	M 10	M 10	150 / 185 mm ²

With UL applications only use 60°/75° copper conductors!

Torques for screw connectors [Nm]

Screw	Min	Rated	Max
M 2	0.22	0.25	0.28 (Phoenix terminals)
M 4	0.85	1.3	1.7
M 6	2.95	4.4	5.9
M 8	11.5	17	22.5
M10	22	33	44

Ventilation data

230V, 50-60Hz

Thyro-A	Type current 50 Hz	Type current 60 Hz	Air volume
1A 280 F	0.13 A	0.13 A	120 m ³ /h
2A 280 F	0.25 A	0.26 A	200 m ³ /h

The ventilators must run with Thyro-A switched on, connection to X7

➔ 11. Dimensional drawings

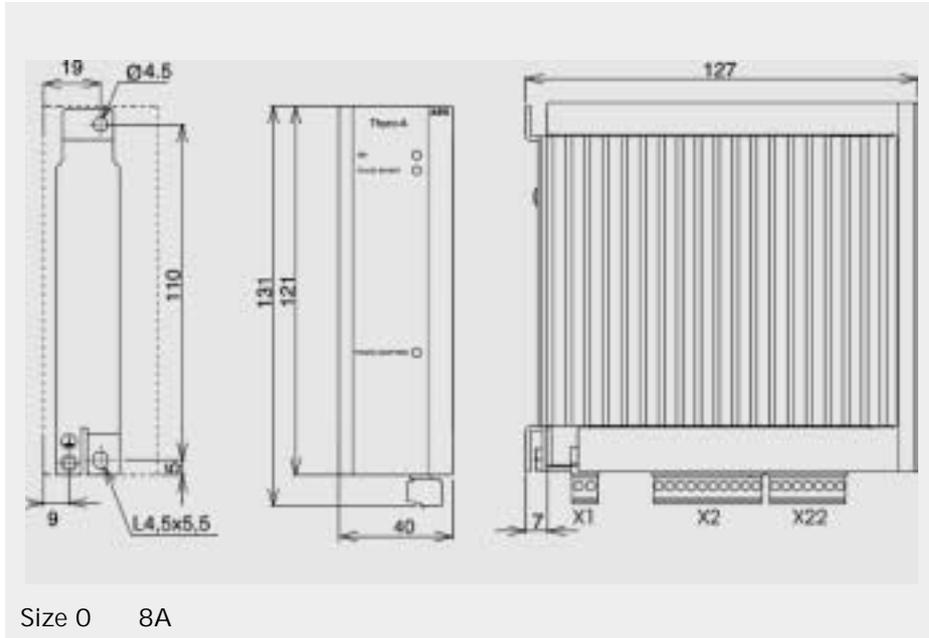

Dimensional drawing 910

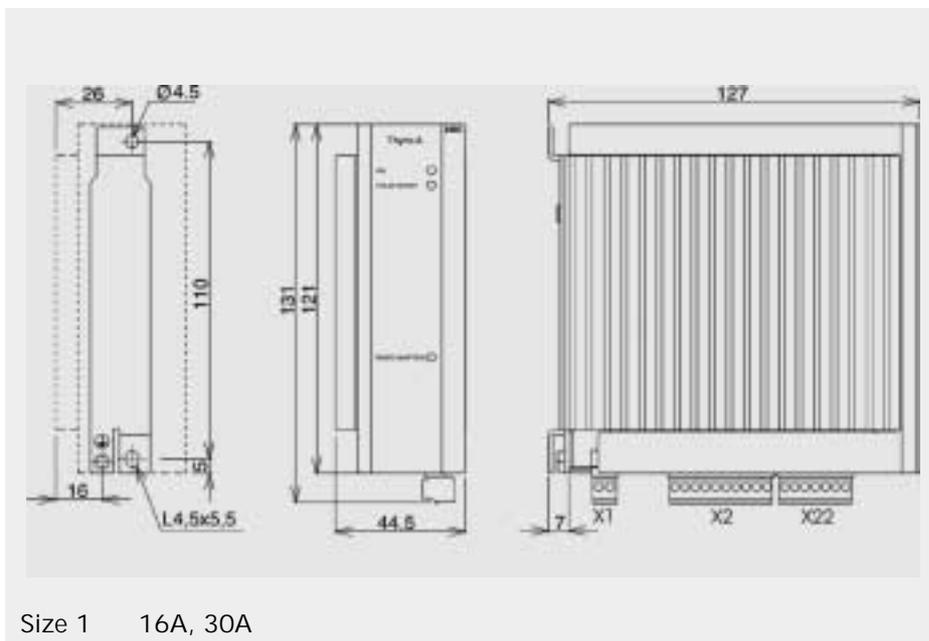

Dimensional drawing 911

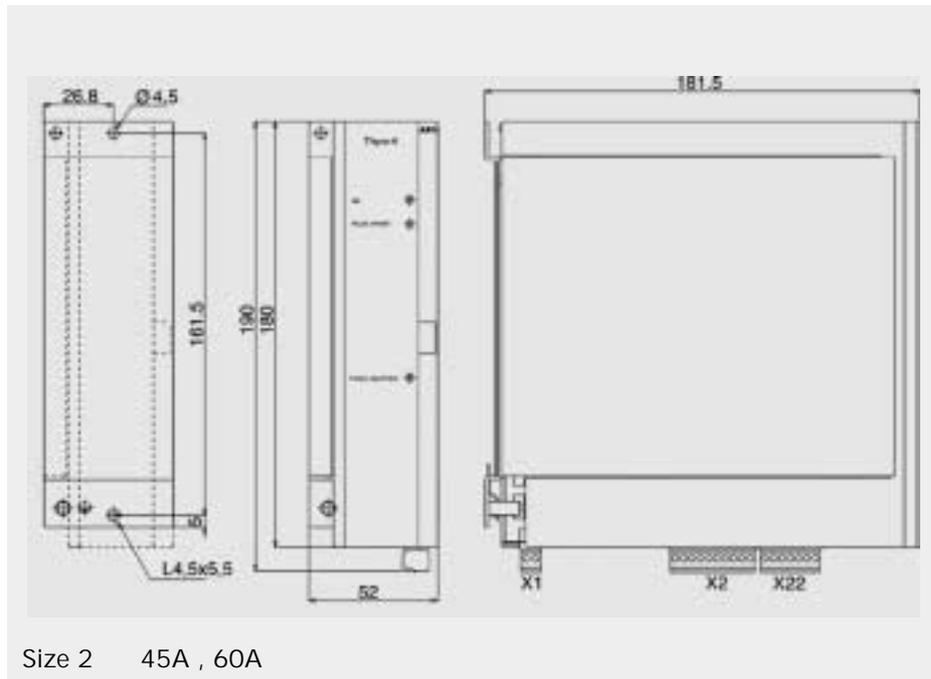

Dimensional drawing 943

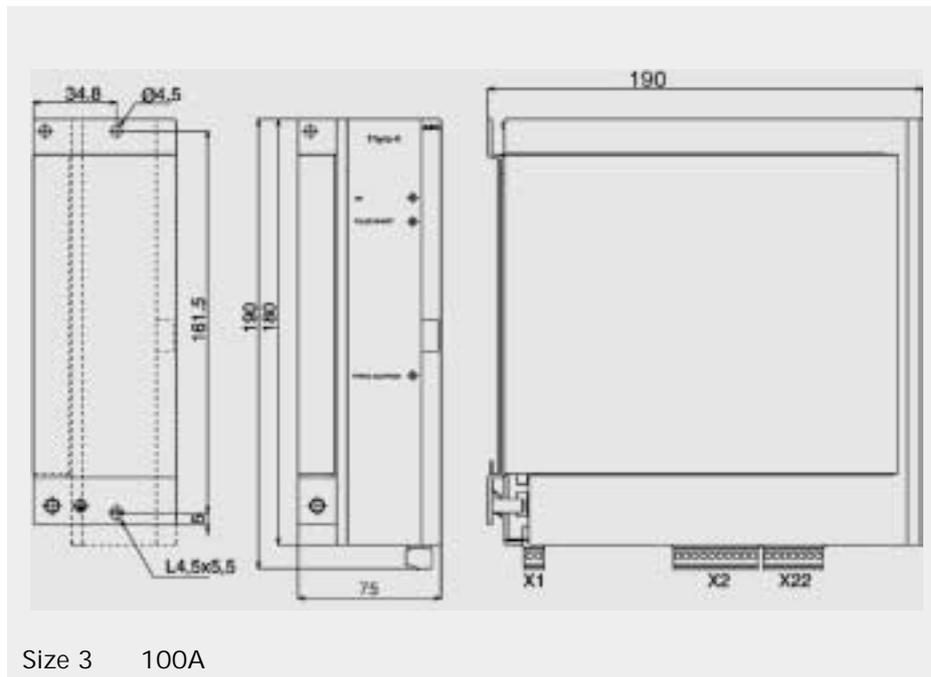

Dimensional drawing 944

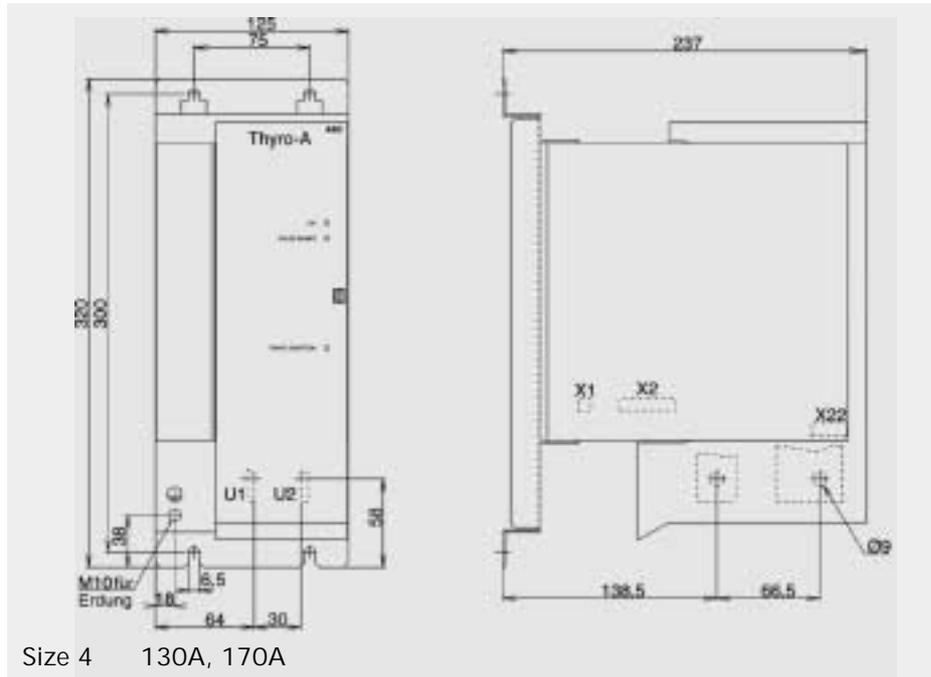

Dimensional drawing 946

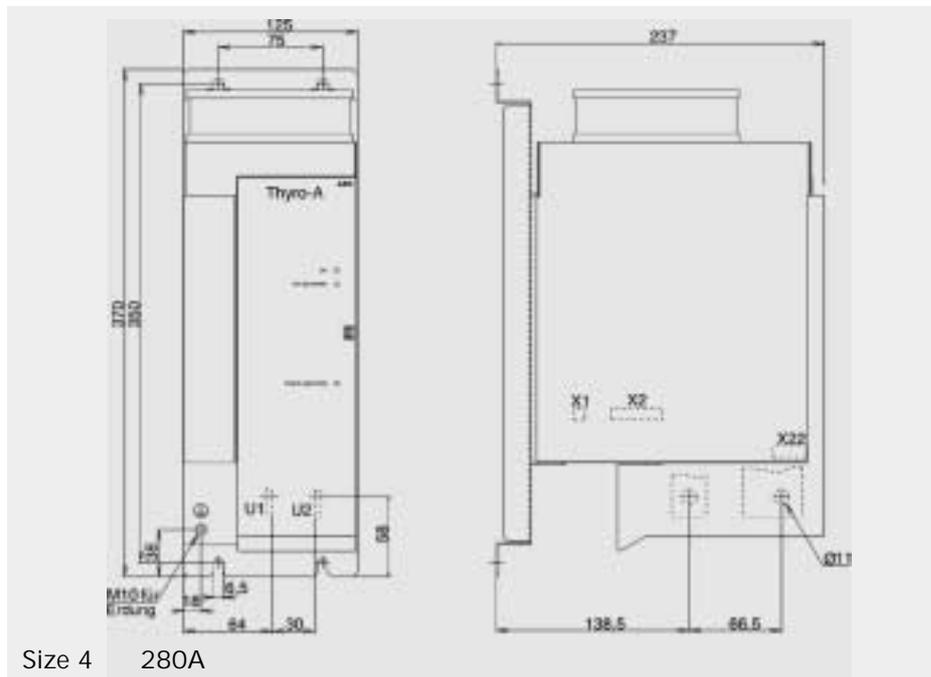

Dimensional drawing 948

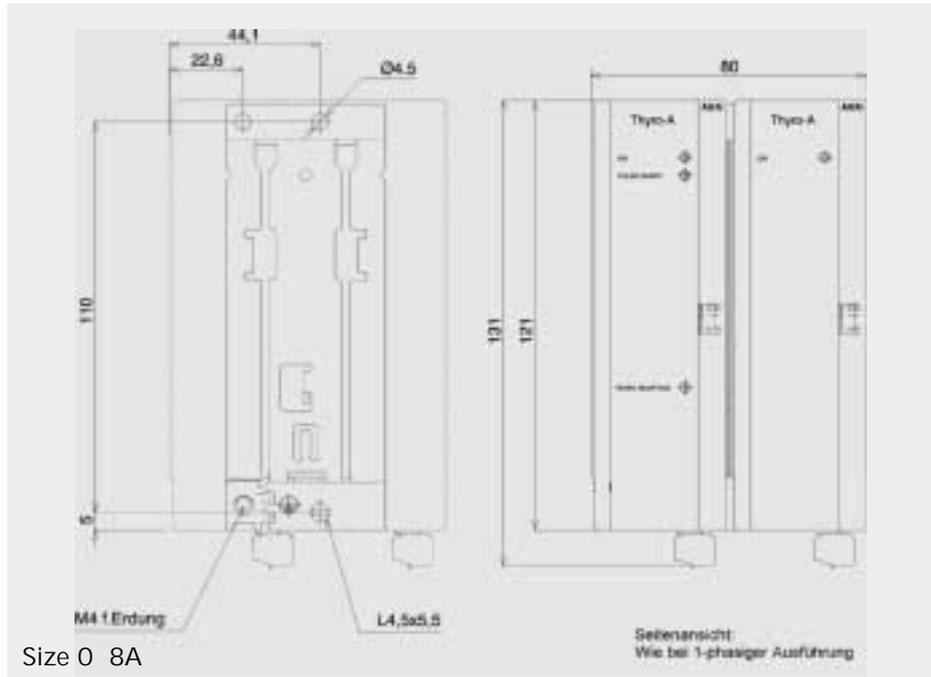

Dimensional drawing 000

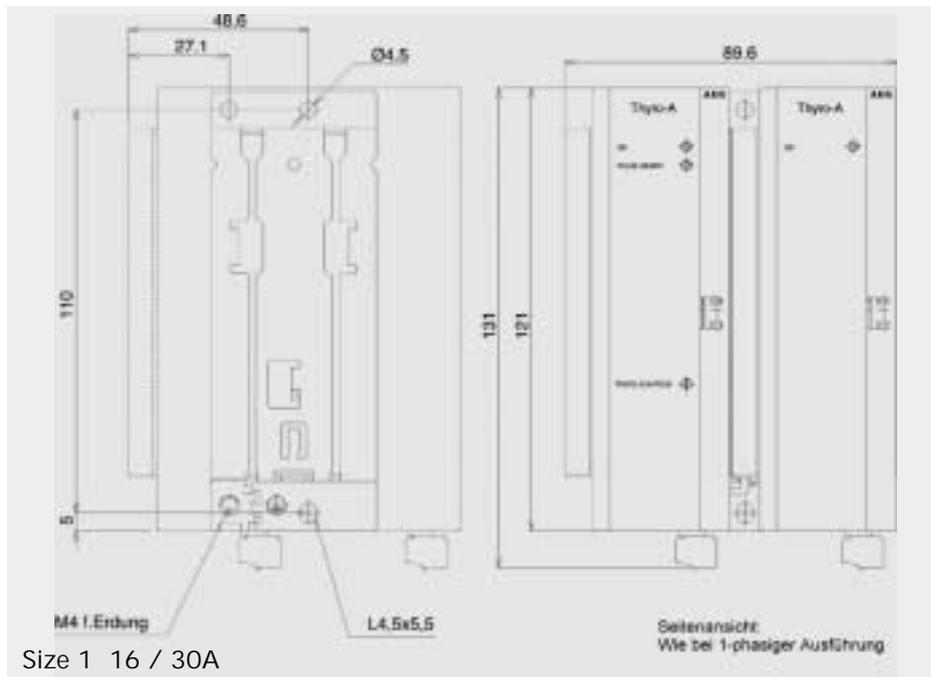

Dimensional drawing 001

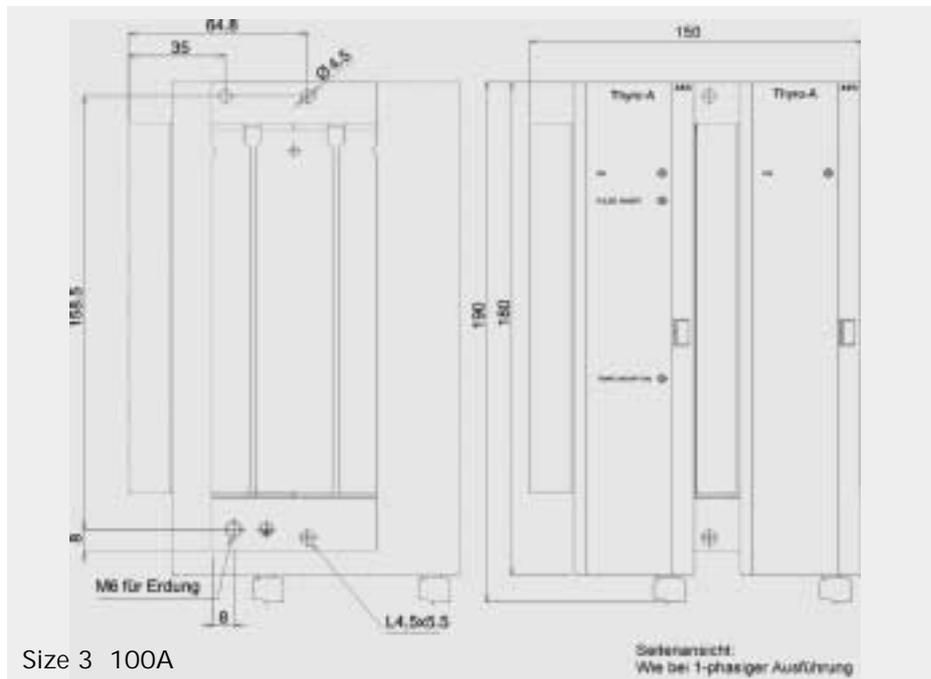
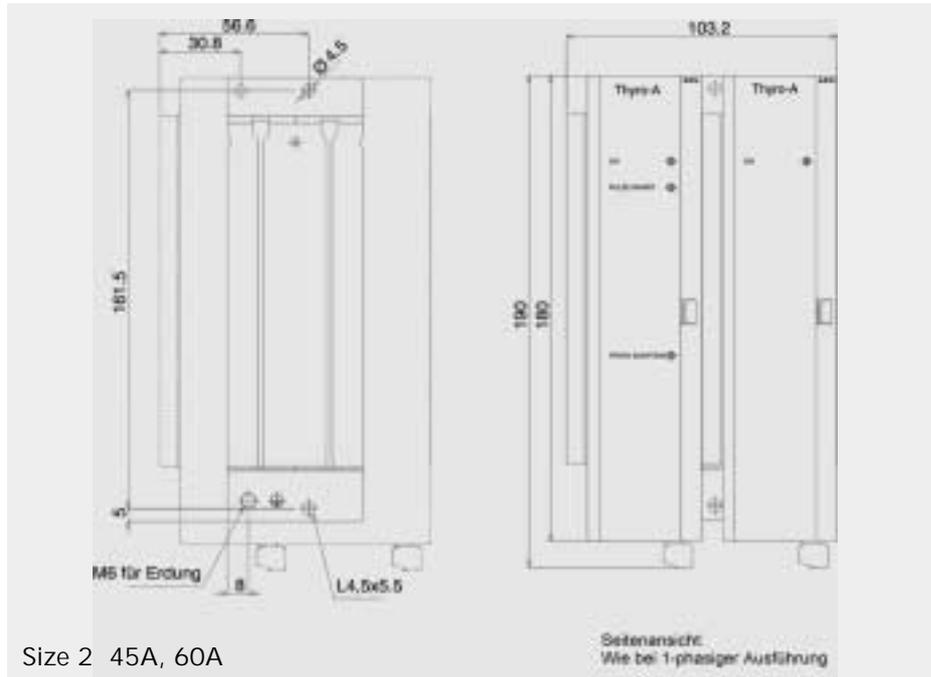

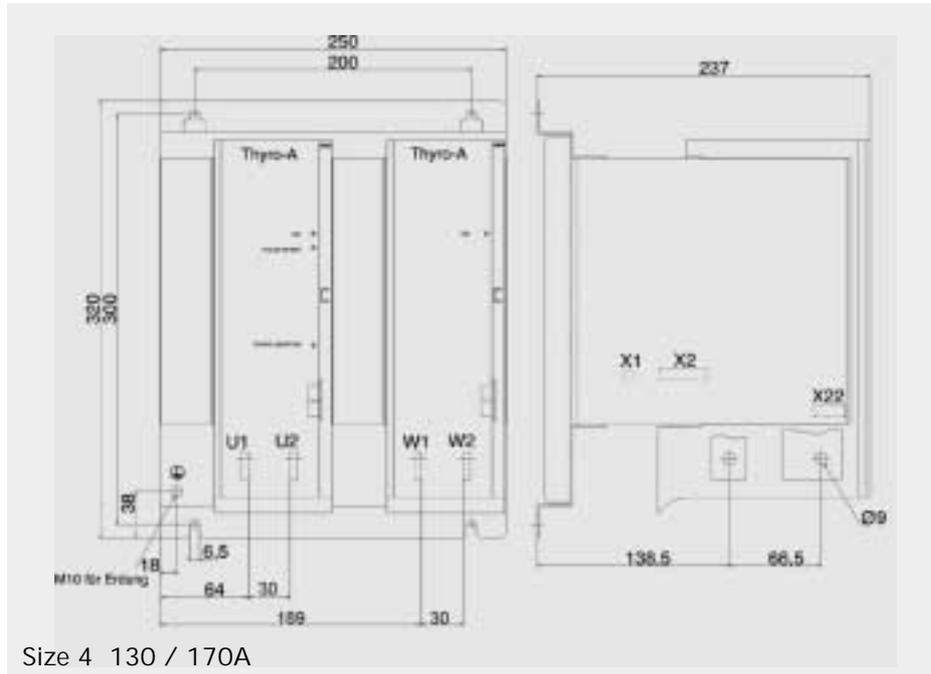

Size 4 130 / 170A

Dimensional drawing 006

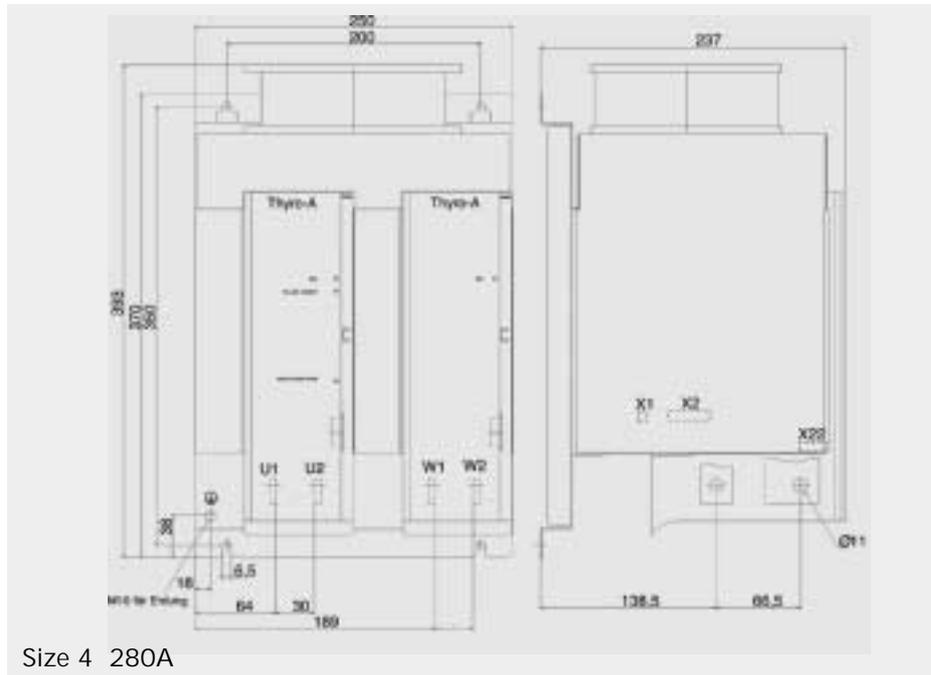

Size 4 280A

Dimensional drawing 008

➔ 12. Accessories and options

Order no. 8000 006 757	Support for 35 mm snap-on assembly for 8A, 16A and 30A
Order no. 2000 000 841	Busmodul Profibus DP
Order no. 2000 000 842	Busmodul Modbus RTU

➔ 13. Approvals and conformities

The following approvals and conformities are available for Thyro-A

- Quality standard according to DIN EN ISO 9001
- UL registration, file no. E 135074, under preparation, with consideration to Canadian National Standard, project no. 02ME08043
- CE conformity
- Low voltage directive 73/23 EEC
- EMV directive 89/336 EEC; 92/31 EEC
- Marking directive 93/68 EEC

There is no product norm for Thyristor Power Controllers so that a sensible norm structure must be set up which ensures safe application and opportunity for comparison.



CAUTION

Thyristor Power Controllers are not devices for disconnection in the sense of DIN VDE 0105 T1 and may therefore be operated only in connection with a suitable mains isolating device (e.g. switch, isolating link).

Further norms are adhered to, e.g. voltage dips according to 61000-4-11:8.94 are ignored by the control device or registered by triggering off monitoring. Generally an automatic start is made after the mains returns within the tolerances.

In detail

Conditions for use	
Built-in unit (VDE 0160)	DIN EN 50 178
General requirements	DIN EN 60146-1-1:12.97
Design, vertical installation	
Operating conditions	DIN EN 60 146-1-1; K. 2.5
Operating location, industry sector	CISPR 6

Temperature behaviour		DIN EN 60 146-1-1; K 2.2
Storage temperature	D	-25°C - +55°C
Transport temperature	E	-25°C - +70°C
Operating temperature	better B	-10°C - +35°C with external cooling (280A) -10°C - +45°C for self air cooling -10°C - +55°C with reduced type current -2%/°C
Load class	1	DIN EN 60 146-1-1 T.2
Humidity class	B	DIN EN 50 178 Tab. 7 (EN 60 721)
Overtoltage category	III	DIN EN 50 178 Tab. 3 (849V)
Degree of pollution	2	DIN EN 50 178 Tab. 2
Air pressure		900 mbar * 1000m above NN
Protection class	I	DIN EN 50178 Chap. 3
Safe isolation		
Up to 500 V mains voltage		DIN EN 50 178 Chap. 3
Air and creeping distances		casing / mains potential > 5.5 mm casing / control potential > 2.5 mm mains voltage /contr. potent. ≥ 10 mm mains volt. interactive 2.5 mm
Mechanical impact		DIN EN 50 178 Chap. 6.2.1
Test voltage		DIN EN 50 178 Tab. 18
Tests according to		DIN EN 60 146-1-1 4.
EMV noise emission		EN 61000-6-4
Noise suppr. control device	Class A	DIN EN 55011:3.91 CISPR 11
EMV noise resistance		EN 61000-6-2
Compatibility level	Class 3	EN 61000-2-4:7.95
ESD	8 kV (A)	EN 61000-4-2:3.96
Electromagnetic fields	10 V/m	EN 61000-4-3:3.95
Burst mains lines	2 kV (A)	EN 61000-4-4:.95
control lines	2 kV (A)	
Surge mains lines	2 kV unsym.	EN 61000-4-5:.95
	1 kV sym.	EN 61000-4-5:.95
control lines	0.5 kV	
Line-conducted		EN 61000-4-6



Weltweit ist **AEG SVS** auf allen wichtigen
Märkten durch Vertriebspartner vertreten.

AEG SVS is represented by sales partners
in all important markets world wide.

Die aktuellen regionalen Adressen finden Sie im Internet: <http://www.aegsvs.de>
You can find the current addresses on the Internet: <http://www.aegsvs.de>

AEG SVS
Power Supply Systems GmbH

A company of Saft Power
Systems

Emil-Siepmann-Straße 32

D-59581 Warstein-Belecke

Tel. +49(0)2902/763-509

Phone +49(0)2902/763-278

Fax +49(0)2902/763-1201

<http://www.aegsvs.de>



<http://www.saftpowersystems.com>