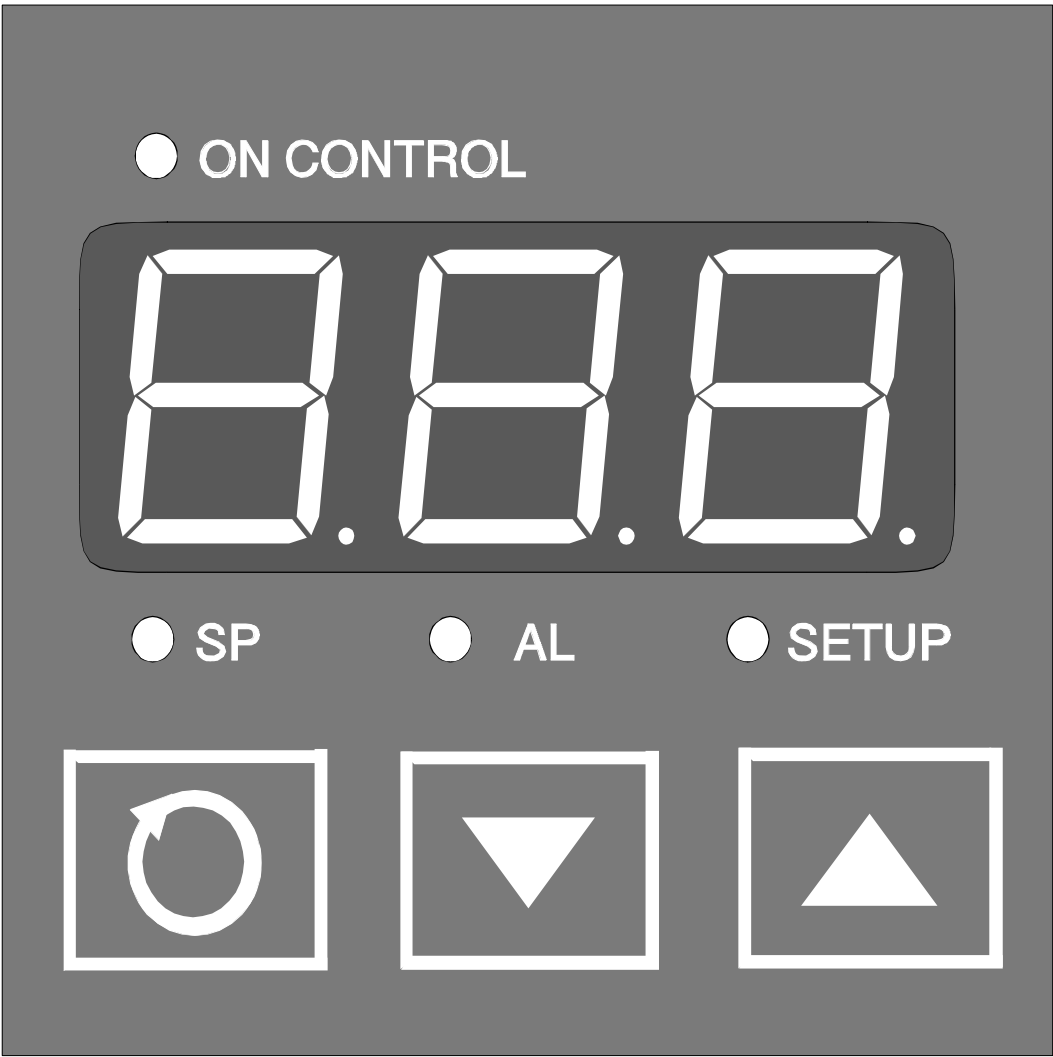


$\frac{1}{16}$ -DIN  
PACKAGING CONTROLLER  
SITE MANUAL



59106-3

May 2017

# PREFACE

This manual is intended for use in support of the installation and commissioning of the  $\frac{1}{16}$ -DIN Packaging Controller.



## CAUTION

The international hazard symbol is inscribed adjacent to the rear connection terminals. It is important to read the Site Manual before installing or commissioning the unit. The procedures described in this volume must be undertaken by technically competent personnel.

### Safety and Warning Symbols



Risk of electric shock.



Caution, refer to the manual.

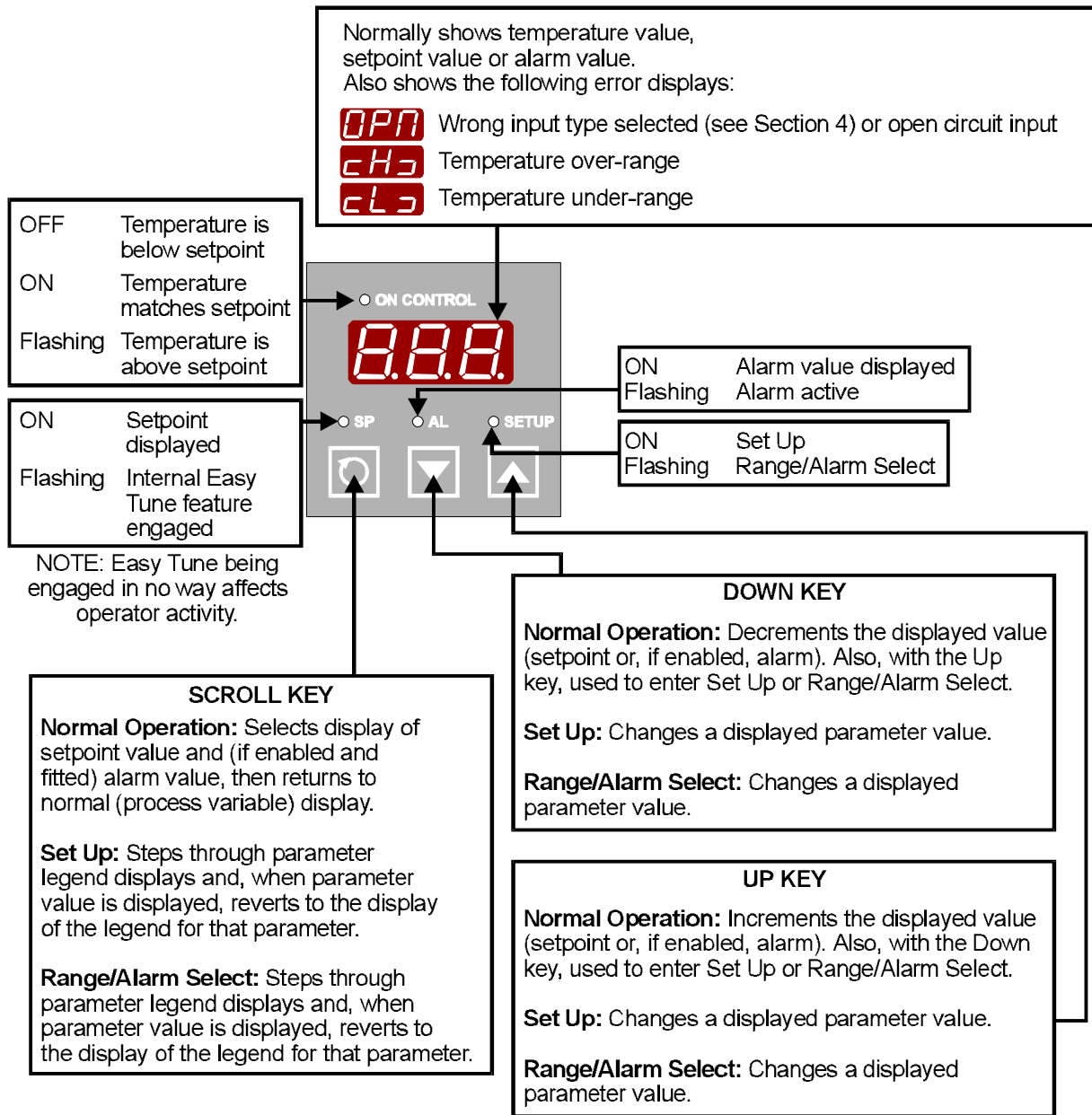


Alternating or direct current  
could be present.



Equipment protected through-out  
by double insulation.

## SECTION 1 FRONT PANEL



## SECTION 2 INSTALLATION - PANEL-MOUNTING

### 2.1 UNPACKING THE INSTRUMENT

1. Remove the Controller from its packing. The Controller is supplied with a panel gasket and a no tools required fixing strap. Retain the packing for future use (e.g. moving the Controller to a different site).
2. Examine the delivered items for damage or deficiencies. If any is found, notify the carrier immediately.

### 2.2 PREPARING THE MOUNTING PANEL

The mounting panel must be rigid and may be up to 6.0mm (0.25 inches) thick. The cut-out required for a single instrument is shown in Figure 2-1. The Controller is 100mm deep (measured from the rear face of the front panel). The front panel is 48mm wide and 48mm high. The front panel projects 10mm from the mounting panel. The main dimensions of the Controller are shown in Figure 2-2.

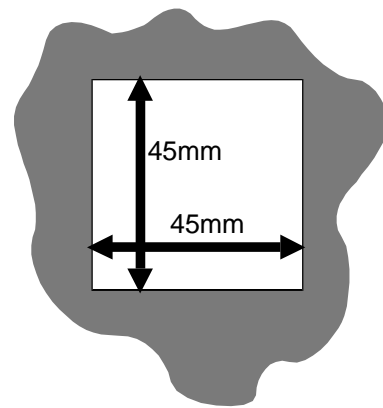


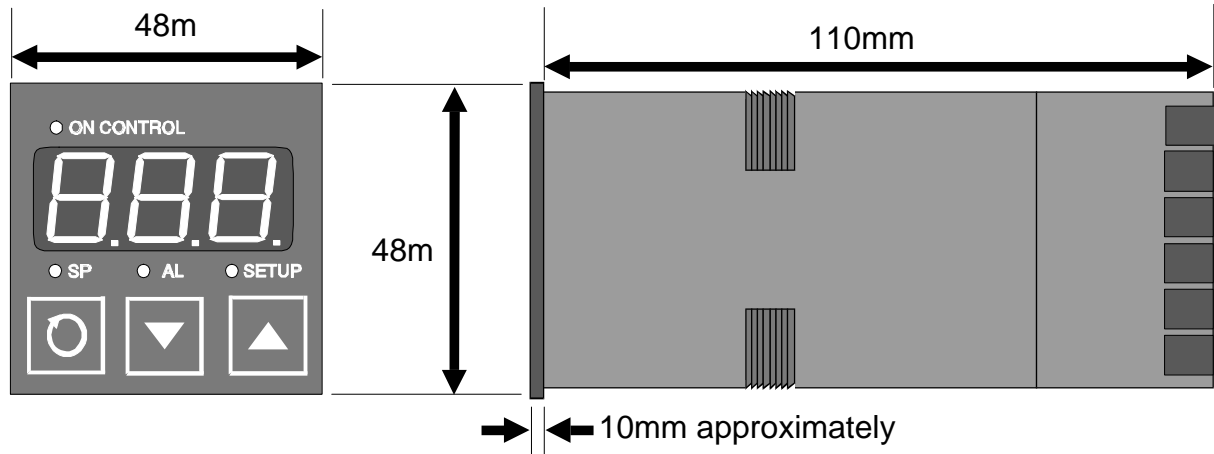
Figure 2-1 Cut-out Dimensions

### 2.3 INSTALLING THE CONTROLLER IN THE MOUNTING PANEL

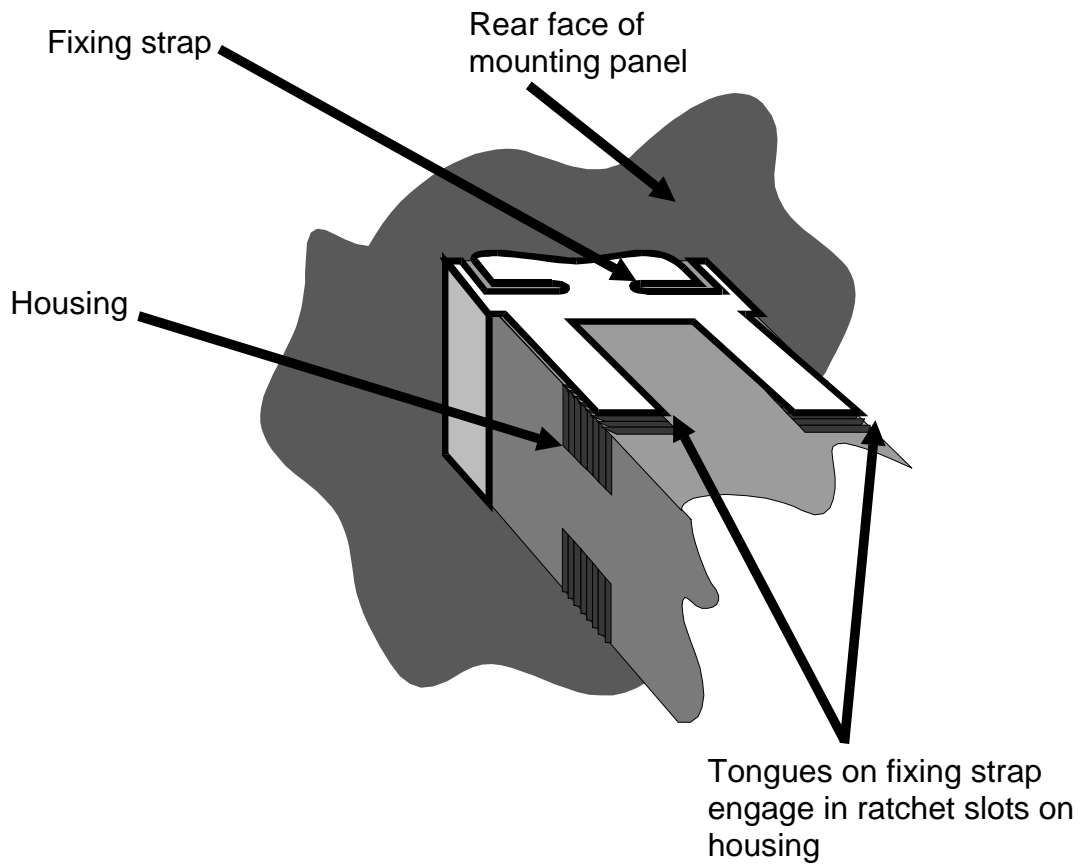
1. From the front of the mounting panel, insert the rear of the Controller housing into the cut-out on the mounting panel.
2. Hold the Controller lightly in position against the panel. Ensure that the panel gasket is not distorted and that the Controller is positioned squarely against the panel. Apply pressure to the front panel bezel only.

**CAUTION:** Do not remove the front panel gasket from the Controller, as this may cause inadequate clamping of the Controller to the mounting panel.

3. Slide the fixing strap into place (see Figure 2-3) and push it forward until it is in firm contact with the rear face of the mounting panel (the fixing strap should now hold the Controller firmly in place).

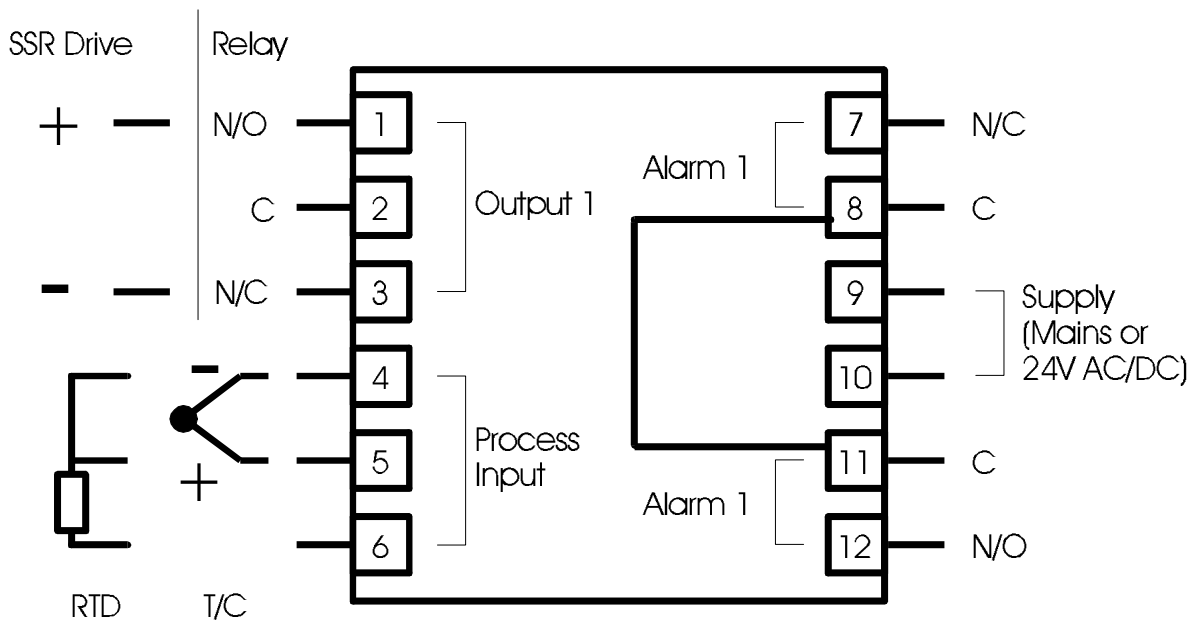


**Figure 2-2 Main Dimensions**



**Figure 2-3 Panel-mounting the Controller**

### SECTION 3 INSTALLATION - WIRING CONNECTIONS

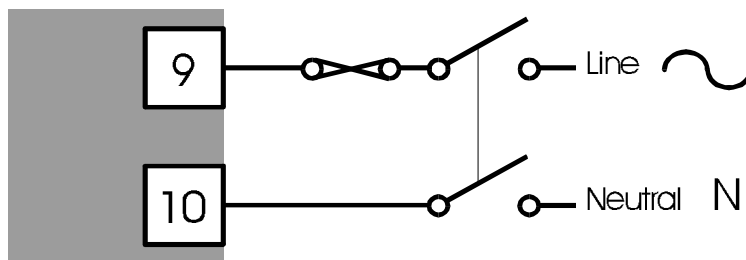


**Figure 3-1 Rear Terminals**

#### 3.1 MAINS (LINE) SUPPLY

This version of the Controller will operate on a 96 - 264V AC 50/60Hz mains (line) supply. The power consumption is approximately 4VA.

**CAUTION:** This equipment is designed for installation in an enclosure which provides adequate protection against electric shock. Local regulations regarding electrical installation should be rigidly observed. Consideration should be given to prevention of access to the power terminations by unauthorised personnel. Power should be connected via a two-pole isolating switch (preferably situated near the Controller) and a 1A fuse, as shown in Figure 3-1.



**Figure 3-2 Mains (Line) Supply Connections**

If the contacts of the relay output(s) are used to carry mains (line) voltage, it is recommended that the relay contacts mains (line) supply should be switched and fused in a similar manner but should be separate from the Controller mains (line) supply.

### 3.2 24V (NOMINAL) AC/DC SUPPLY

The supply connections for the 24V AC/DC version of the Controller are as shown in Figure 3-3. Power should be connected via a two-pole isolating switch and a 315mA slow-blow (anti-surge Type T) fuse. This version of the Controller will accept the following supply ranges:

24V (nominal) AC 50/60Hz -	20 - 50V
24V (nominal) DC -	22 - 65V

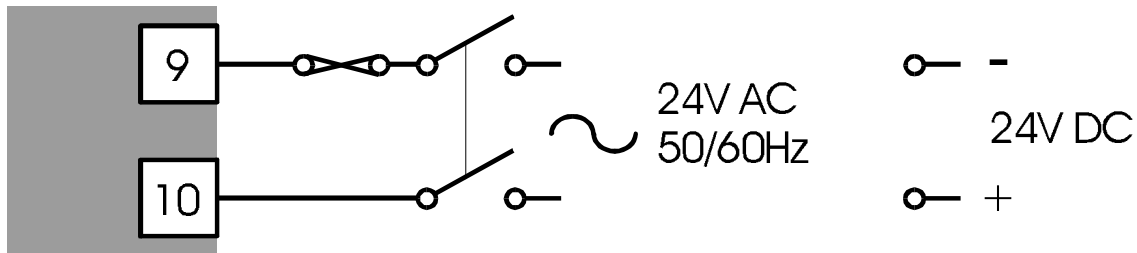


Figure 3-3 24V AC/DC Supply Connections

### 3.3 THERMOCOUPLE INPUT

The correct type of thermocouple extension leadwire or compensating cable must be used for the full distance between the Controller and the thermocouple, ensuring that the correct polarity is observed throughout. Joints in the cable should be avoided, if possible.

NOTE: Do not run thermocouple cables adjacent to power-carrying conductors. If the wiring is run in a conduit, use a separate conduit for the thermocouple wiring. If the thermocouple is grounded, this must be done at one point only. If the thermocouple extension lead is shielded, the shield must be grounded at one point only.

### 3.4 RTD INPUTS

The compensating lead should be connected to Terminal 4. For two-wire RTD inputs, Terminals 4 and 5 should be linked. The extension leads should be of copper and the resistance of the wires connecting the resistance element should not exceed 5 ohms per lead (the leads should be of equal length).

### 3.5 RELAY OUTPUTS

The contacts are rated at 2A resistive at 120/240V AC.

### 3.6 SSR DRIVE OUTPUT

This output produces a time-proportioned non-isolated DC signal (0 - 10V nominal, into 500Ω minimum).

## SECTION 4 SETTING UP - RANGE/ALARM SELECTION

Press the Scroll and Up keys simultaneously until the display starts to flash. Release the Scroll and Up keys then press the Down key. The **SET UP** indicator will flash and the display will show the legend for the first parameter; after 1.5 seconds, the value of that parameter will be displayed. Use the Scroll key to step through the parameters in the sequence shown below and opposite.


**NOTES ON USE OF SCROLL KEY:** When a legend is displayed, pressing this key will step to the legend for the next parameter; when a value is displayed, pressing this key will display the legend for that parameter.

### 4.1 CHANGING PARAMETER VALUES/SETTINGS

Use the Up and Down keys to change the displayed value/setting. All changes are implemented immediately.

### 4.2 RETURNING TO NORMAL OPERATION

Press the Scroll key to display a parameter legend. While this legend is still displayed, press the Up and Down keys simultaneously for three seconds. **NOTE:** An automatic return to normal operation occurs if there is no key activity in Range/Alarm Selection Mode for one minute.

Parameter	Displayed Legend	Available Values																																								
Input Type and Range	I nP	<div style="display: flex; flex-direction: column; align-items: center;"> <div style="display: flex; justify-content: space-around; width: 100%;"> <div style="text-align: center;"> <p>Three-digit display</p>  </div> <div style="text-align: center;"> <p>Input Range Maximum <sup>1</sup></p> <table border="1"> <thead> <tr> <th>Value</th> <th>Max.</th> <th>Value</th> <th>Max.</th> </tr> </thead> <tbody> <tr> <td>1</td> <td>100</td> <td>5</td> <td>500</td> </tr> <tr> <td>2</td> <td>200</td> <td>6</td> <td>600</td> </tr> <tr> <td>3</td> <td>300</td> <td>7</td> <td>700</td> </tr> <tr> <td>4</td> <td>400</td> <td>8</td> <td>800</td> </tr> </tbody> </table> </div> </div> <div style="display: flex; justify-content: space-around; width: 100%; margin-top: 10px;"> <div style="text-align: center;"> <p>Input Sensor Type</p> <table border="1"> <thead> <tr> <th>Value</th> <th>Units</th> </tr> </thead> <tbody> <tr> <td>1</td> <td>Thermocouple Type J/L</td> </tr> <tr> <td>2</td> <td>Thermocouple Type K</td> </tr> <tr> <td>3</td> <td>Thermocouple Type N</td> </tr> <tr> <td>4</td> <td>Thermocouple Type T <sup>2</sup></td> </tr> <tr> <td>5</td> <td>RTD (-50 to Range Max.)</td> </tr> <tr> <td>6</td> <td>RTD (0.0 to Range Max. - 1 decimal point)</td> </tr> </tbody> </table> </div> <div style="text-align: center;"> <p>°C or °F</p> <table border="1"> <thead> <tr> <th>Value</th> <th>Units</th> </tr> </thead> <tbody> <tr> <td>0</td> <td>°C</td> </tr> <tr> <td>1</td> <td>°F</td> </tr> </tbody> </table> </div> </div> </div>	Value	Max.	Value	Max.	1	100	5	500	2	200	6	600	3	300	7	700	4	400	8	800	Value	Units	1	Thermocouple Type J/L	2	Thermocouple Type K	3	Thermocouple Type N	4	Thermocouple Type T <sup>2</sup>	5	RTD (-50 to Range Max.)	6	RTD (0.0 to Range Max. - 1 decimal point)	Value	Units	0	°C	1	°F
Value	Max.	Value	Max.																																							
1	100	5	500																																							
2	200	6	600																																							
3	300	7	700																																							
4	400	8	800																																							
Value	Units																																									
1	Thermocouple Type J/L																																									
2	Thermocouple Type K																																									
3	Thermocouple Type N																																									
4	Thermocouple Type T <sup>2</sup>																																									
5	RTD (-50 to Range Max.)																																									
6	RTD (0.0 to Range Max. - 1 decimal point)																																									
Value	Units																																									
0	°C																																									
1	°F																																									



Parameter	Displayed Legend	Available Values
Control Action	CTL	r P Reverse-acting PID control
		d P Direct-acting PID control
		r o Reverse-acting ON/OFF control
		d o Direct-acting ON/OFF control
Alarm Type and Action (available only if an Alarm Option is fitted)	ALT	PHd Process High Alarm, direct-acting
		PLd Process Low Alarm, direct-acting
		dEd Deviation Alarm, direct-acting
		bAd Band Alarm, direct-acting
		PHr Process High Alarm, reverse-acting
		PLr Process Low Alarm, reverse-acting
		dEr Deviation Alarm, reverse-acting
		bAr Band Alarm, reverse-acting
<p>NOTES:</p> <ol style="list-style-type: none"> <li>The RTD 0.0 range will always be 0.0 - 99.9, whatever the Range Maximum setting may be.</li> <li>Absolute Range Maximum = 400°C (700°F).</li> </ol>		

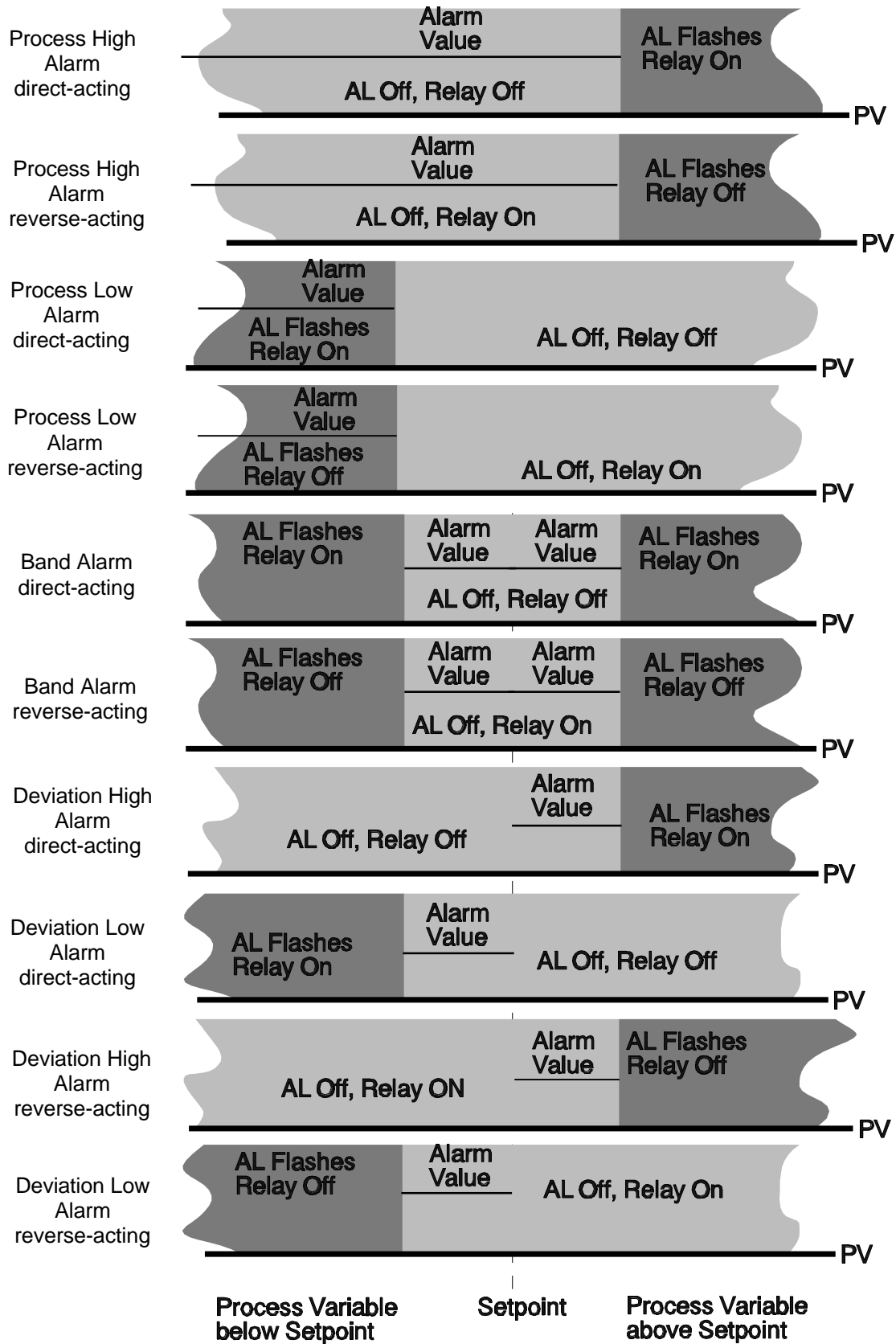


Figure 4-1 Alarm Operation