

# Solid State Relay, 1-phase

## Short-Circuit Proof, heat sink integrated

### Main Characteristics:

- Zero-point switching
- "Short-circuit proof" with miniature circuit-breaker
- LED display
- Various connection technologies
- Plug-in control terminal
- Degree of protection IP 20
- Insulated mounting foot



### Standards / Approvals:

DIN EN 60947-4-3  
UL 508 / CSA

CE  
C-Ti

ck

### Ordering Key:

<b>3RF23</b>	<b>20</b>	<b>- 1</b>	<b>D</b>	<b>A</b>	<b>0</b>	<b>2</b>
Solid state contactor with heat sink	Max. load current 20 = 20 A 30 = 30 A	Connection technology 1 = Screw connection 2 = Spring-loaded connection 3 = Ring cable connection M5	Switching function D = Short-circuit proof, zero-point switching	Controlled phases A = Single-phase	Control voltage 0 = 24 V DC 2 = 110 - 230 V AC 4 = 4 - 30 V DC	Operating voltage 2 = 24 - 230 V 4 = 48 - 460 V

Not all possible versions are available ex stock.

### Main Circuit:

Values for 40 °C ambient temperature!	$I_{AC-51}$	$I_e$ acc. to IEC947-4-3	$I_e$ UL/CSA	Power loss with $I_{max}$	Min. load current	Max. leakage current
Type	A	A	A	W	A	mA
3RF2320- . DA .	20	13.2	17.6	20	0.5	10
3RF2330- 1 DA .	30	18,5	26	29	0,5	10
3RF2330- 3 DA .	30	18,5	26	29	0,5	10

Type		3RF23. 0- . DA . 2	3RF23. 0- . DA . 4
Rated operating voltage $U_e$	V	24 ... 230	48 ... 460
	• Voltage range	V	20 ... 253
	• Rated frequency	Hz	50/60 ± 10 %
Rated insulation voltage $U_i$	V	600	
Rated impulse withstand voltage $U_{imp}$	kV	6	
Blocking voltage	V	800	1200
Slew rate	V/µs	1000	

	Rated impulse withstand strength $I_{tsm}$	$i^2t$ value
Type	A	A <sup>2</sup> s
3RF2320- . DA .	1150	6600
3RF2330- . DA .	1150	6600

<b>Control Circuit:</b>				
Type		3RF23...-DA0.	3RF23...-DA2.	3RF23...-DA4.
<b>Control voltage</b> U <sub>s</sub>	V	24 acc. to EN 61131-2	110 ... 230	4 ... 30 DC
<b>Max. control voltage</b> U <sub>s</sub>	V	30	253	30
<b>Typical operating current</b>	mA	20	15	20
<b>Response voltage</b>	V	15	90	4
<b>Drop-out voltage</b>	V	5	40	1
<b>Rated frequency</b> of the control supply voltage	Hz	--	50/60 ± 10 %	--
<b>Switching times</b> ON delay	ms	1 + max. one half-wave	40 + max. one half-wave	1 + max. one half-wave
OFF delay	ms	1 + max. one half-wave	40 + max. one half-wave	1 + max. one half-wave

<b>General Data:</b>		
<b>Ambient temperature</b>		
During operation	°C	-25 ... 60
During storage	°C	-55 ... 80
<b>Mounting altitude</b>	m	0 ... 1000; at > 1000 m, please contact our Technical Assistance
<b>Impact resistance</b> acc. to DIN IEC 68	g/ms	15/11
<b>Vibration resistance</b>	g	2
<b>Degree of protection</b>		IP20
<b>Electromagnetic compatibility</b>	(EMC)	
Interference emission		
○ Conducted interference voltage IEC 60 947-4-3		Class A for industrial applications <sup>1</sup>
○ Radiated, high-frequency interference voltage IEC 60 947-4-3		Class A for industrial applications
Interference resistance		
○ Electrostatic discharge acc. to IEC 61 000-4-2 (corresponds to severity 3)	kV	Contact discharge 4; air discharge 8; performance criterion 2
○ Induced HF fields acc. to IEC 61 000-4-6	MHz	0.15 ... 80; 140 dBµV; performance criterion 1
○ Burst acc. to IEC 61 000-4-4	kV	2/5.0 kHz; performance criterion 1
○ Surge acc. to IEC 61 000-4-5	kV	Phase-to-ground 2; phase-to-phase 1; performance criterion 2
<b>Dielectric Strength</b> 50/60 Hz (Input, Output / Base)	V rms	4000

Type		3RF23...-1.	3RF23...-2.	3RF23...-3.
<b>Connection, main contacts</b>		<b>Screw connection</b>	<b>Spring-loaded connection</b>	<b>Ring cable connection</b>
<b>Conductor cross-section</b>				
○ Solid	mm <sup>2</sup>	2 x (1.5 ... 2.5), 2 x (2.5 ... 6)	2x (0.5 ... 2.5)	
○ Finely stranded with end sleeve	mm <sup>2</sup>	2 x (1.5 ... 2.5), 2 x (2.5 ... 6), 1 x 10	2x (0.5 ... 1.5)	
○ Finely stranded w/o end sleeve	mm <sup>2</sup>		2x (0.5 ... 2.5)	
○ Solid or stranded	AWG	2 x (14 ... 10)	2 x (18 ... 14)	
<b>Stripping length</b>	mm	10	10	
<b>Terminal screw</b>		M 4	-	M 5
○ Tightening torque	Nm	2 ... 2.5	-	2 ... 2.5
D 5...6 mm / PZ 2	lb.in	18 ... 22	-	18 ... 22
<b>Cable lug</b> DIN		-	-	DIN 46234 5-2.5 ... 5-25 <sup>2</sup>
JIS		-	-	JIS C 2805 R 2-5 ... 14-5

<sup>1</sup> **Attention!**

This product was constructed as a EMC Class A device. The use of this product in residential applications could lead to radio interferences. In such an application, additional filtering may be required.

<sup>2</sup> Maximum breadth of the Cable lug 12 mm!

Type		3RF23...-1.	3RF23...-2.	3RF23...-3.
Connection, auxiliary/control contacts		Screw connection	Spring-loaded connection	Ring cable connection
Conductor cross-section with or without end sleeve	mm <sup>2</sup> mm <sup>2</sup> AWG	1 x (0.5 ... 2.5) 2 x (0.5 ... 1.0) 20 ... 12	0.5 ... 2.5	1 x (0.5 ... 2.5) 2 x (0.5 ... 1.0) 20 ... 12
Stripping length	mm	7	10	7
Terminal screw		M 3	-	M 3
○ Tightening torque	Nm	0.5 ... 0.6	-	0.5 ... 0.6
D 3.5 / PZ 1	lb.in	4.5 ... 5.3	-	4.5 ... 5.3

### Semiconductor Protection in Fuseless Designs

The following miniature circuit-breakers with B characteristic and breaking capacity of 10 kA protect the 3RF2320-.DA.. solid state contactors against short-circuits at the load in accordance with the stated conductor cross-sections and lengths:

Rated current of the miniature circuit-breaker	Example Type <sup>3</sup>	Max. conductor-cross section	Min. conductor length from the contactor to the load
6 A	5SY4106-6	1 mm <sup>2</sup>	5 m
10 A	5SY4110-6	1.5 mm <sup>2</sup>	8 m
16 A	5SY4116-6	1.5 mm <sup>2</sup>	12 m
16 A	5SY4116-6	2.5 mm <sup>2</sup>	20 m
20 A	5SY4120-6	2.5 mm <sup>2</sup>	20 m
25 A	5SY4125-6	2,5 mm <sup>2</sup>	26 m

### Fused Design with Cable and Conductor Protection Fuse with Semiconductor Protection

Rated current of the miniature circuit-breaker	LV HBC design gL/gG 3NA	10x38 gL/gG 3NW	14x51 gL/gG 3NW	22x58 gL/gG 3NW	Diased fast 5SB1	
6 A	1.0 mm <sup>2</sup>	3NA6801	3NW6001-1	3NW6101-1	--	5SB131
10 A	1.0 mm <sup>2</sup>	3NA6803	3NW6003-1	3NW6103-1	3NW6203-1	5SB151
16 A	1.5 mm <sup>2</sup>	3NA6805	3NW6005-1	3NW6105-1	3NW6205-1	5SB161
20 A	2.5 mm <sup>2</sup>	3NA6807	3NW6007-1	3NW6107-1	3NW6207-1	5SB171
25 A	4,0 mm <sup>2</sup>	3NA6810	3NW6010-1	3NW6116-1	3NW6210-1	5SB181
32 A	6,0 mm <sup>2</sup>	3NA6812		3NW6112-1		

### Accessories

Function module	Order No.	Applicable for the following types	Versions
Converter	3RF2900-0EA18	3RF2320-.DA0.	Us = 24 V DC
Load monitoring Basic	3RF2920-0FA08	3RF2320-1DA0.	Screw connection, Us = 24 V DC
Load monitoring Extended <sup>4</sup>	3RF29...-0GA..	3RF23...-1. 3RF23...-3.	Screw connection Ring cable connection
Terminal cover <sup>5</sup>	3RF2900-3PA88	3RF23...-1. 3RF23...-3.	Screw connection Ring cable connection

<sup>3</sup> Maximum voltage 480 V according UL1077 and CSA 22.2, please refer to catalog ET B1

<sup>4</sup> For the exact allocation of the function modules, please refer to the LV 1 Catalog.

<sup>5</sup> The terminal cover must be adjusted for screw connection applications.

## Characteristic Curves

3RF2320-

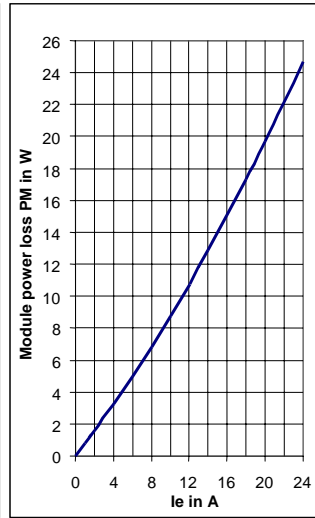
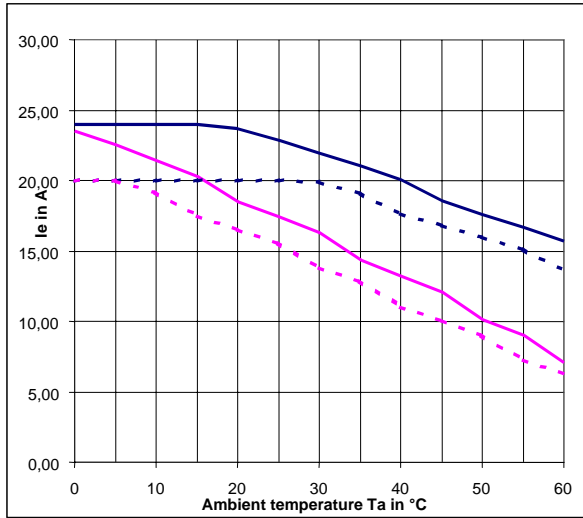

**Upper curves:**

$I_{max}$  thermal  
limit current

**Lower curves:**

Rated current  $I_e$   
acc. to

DIN EN 60947-4-3

**Continuous lines:**

Stand-alone mounting

**Dashed lines:**

Side-by-side mounting

3RF2330-

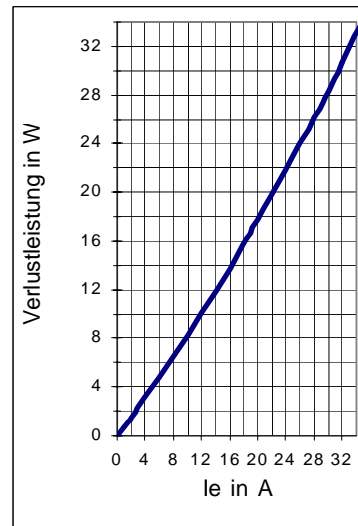
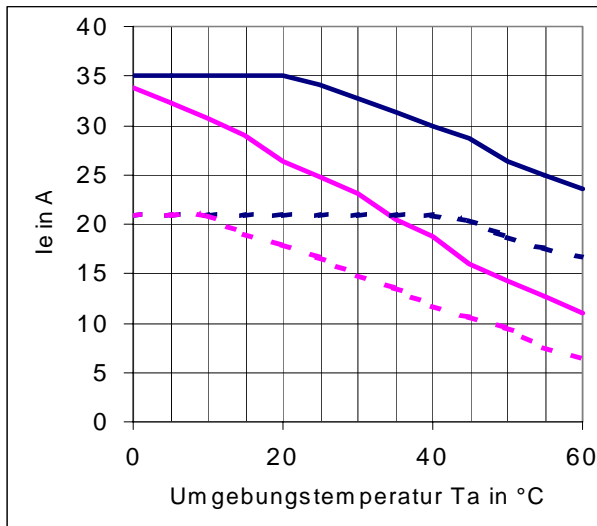

**Mounting Instructions <sup>6</sup>:**

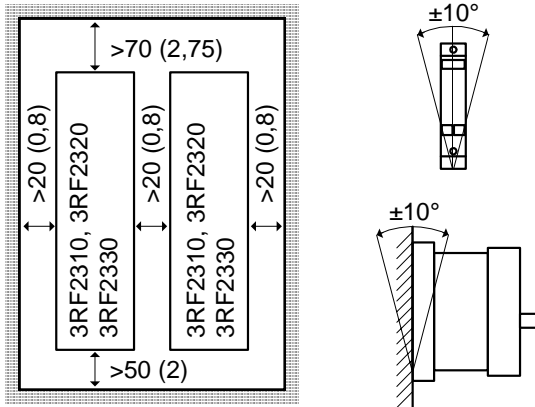

**Dimension Drawings :**

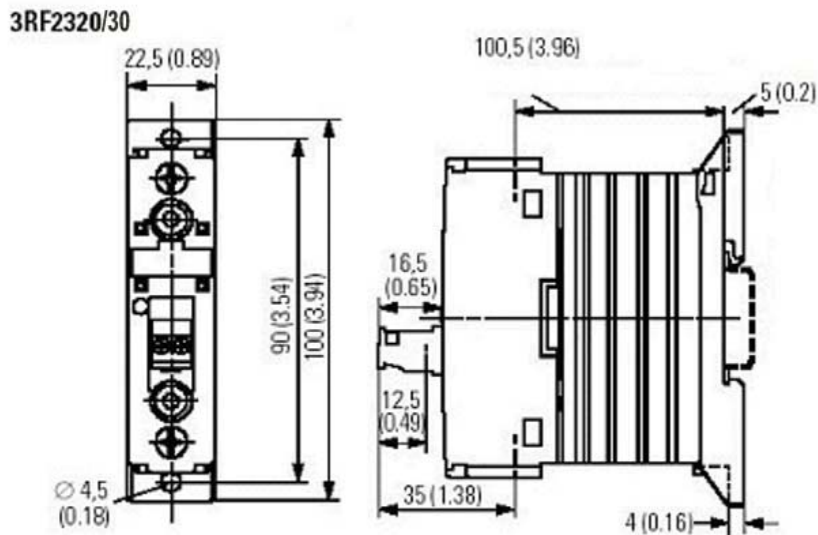

<sup>6</sup> Dimensions in mm, (in);  
 Stand-alone mounting, characteristic curves show derating for side-by-side mounting  
 Subject to changes

**Device / Example Circuit Diagram:**

3RF23...-DA0. / .DA4.  
 Us = DC 24 V / DC 4 ...30 V

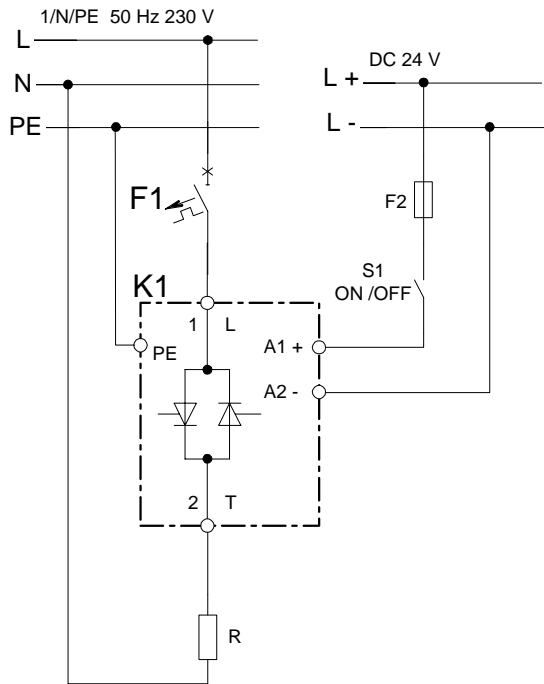

3RF23...-DA2.  
 Us = AC 110 ... 230

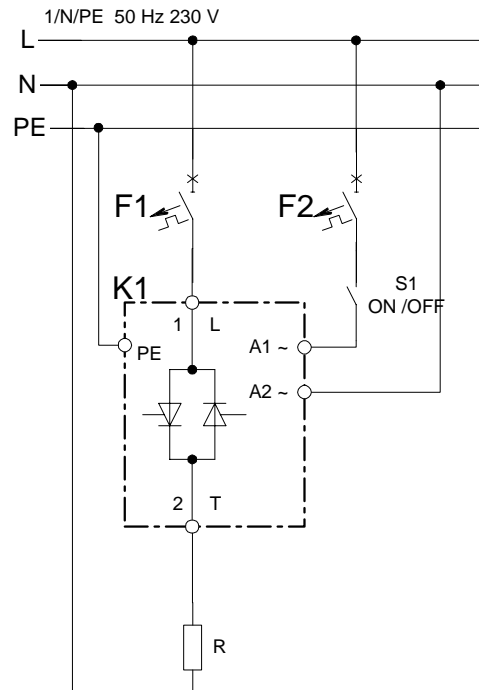

- F1 Main circuit fuse
- F2 Miniature circuit-breaker with B characteristic
- K1 3RF23 solid state contactor
- R Load resistance



**Deutschland**  
 Prozeß- und Maschinen- Automation GmbH  
 P.O. Box 31 02 29  
 D-34058 Kassel  
 Tel.: +49 - 561- 505 1307  
 Fax: +49 - 561- 505 1710  
 E-mail: mailbox@pma-online.de  
 Internet: http://www.pma-online.de

**Österreich**  
 PMA Prozeß- und Maschinen-Automation GmbH  
 Zweigniederlassung Österreich  
 Triester Str. 64, A-1100 Wien  
 Tel.: +43 - 1- 60101- 1865  
 Fax: +43 - 1- 60101- 1911  
 E-mail: info@pma-online.at  
 Internet: http://www.pma-online.at